

SEPTEMBER 2020



## **USER'S MANUAL**

PRESSURE TRANSMITTERS

**PCE-28, PCE-28.Smart, PCE-28 Ex Safety**

**PC-29A, PC-29B, PCE-28.Modbus**

DIFFERENTIAL PRESSURE TRANSMITTERS

**PRE-28, PRE-28.Smart, PRE-28 Ex Safety**

**PR-29A, PR-29B, PRE-28.Modbus**





**Flameproof (Exd) version**

APLISENS S.A., 03-192 Warsaw, Morelowa 7 St.

tel. +48 22 814 07 77; fax +48 22 814 07 78

[www.aplisens.com](http://www.aplisens.com), e-mail: [export@aplisens.com](mailto:export@aplisens.com)

## Symbols used

Symbol	Description
	Warning to proceed strictly in accordance with the information contained in the documentation in order to ensure the safety and full functionality of the device.
	Information particularly useful during installation and operation of the device.
	Information particularly useful during installation and operation of Ex versions.
	Information on disposal of used equipment.

## BASIC REQUIREMENTS AND SAFE USE



- The manufacturer will not be liable for damage resulting from incorrect installation, failure to maintain the device in a suitably functional condition, or use of the device other than for its intended purpose.
- Installation should be carried out by qualified personnel having the necessary authorisation to install electrical and pressure measuring devices. The installer is responsible for performing the installation in accordance with instructions and with the electromagnetic compatibility and safety regulations and standards applicable to the type of installation.
- In the installation with control and measurement instruments exists, in case of leakage, a risk to personnel on the side where the medium is under pressure. All safety and protection requirements must be observed during installation, operation and inspections.
- If a device is not functioning correctly, disconnect it and send it for repair to the manufacturer or to a firm authorised by the manufacturer.



- In order to minimise the risk of malfunction and associated risks to personnel, the device is not to be installed or used in particularly hostile conditions, where the following risks occur:
- Possibility of mechanical impacts, excessive shocks and vibration;
  - Excessive temperature fluctuation;
  - Condensation of water vapour, dust, icing.



When using the device in potentially explosive areas, observe technical requirements specified in manual and applicable local (national) regulations.

Changes made to the manufacturing of products may be introduced before the paper version of the manual is updated. The up-to-date manuals are available on the manufacturer's website: [www.aplisens.com](http://www.aplisens.com)

## CONTENTS

<b>1. INTRODUCTION .....</b>	<b>5</b>
<b>2. SAFETY .....</b>	<b>6</b>
<b>3. USER INFORMATION.....</b>	<b>6</b>
<b>4. TRANSPORT AND STORAGE .....</b>	<b>6</b>
4.1. Transport.....	6
4.2. Storage.....	6
<b>5. GUARANTEE .....</b>	<b>7</b>
<b>6. CONSTRUCTION.....</b>	<b>7</b>
6.1. Intended use and functions .....	7
6.2. Construction and dimensions .....	7
6.3. Identification .....	10
<b>7. USING OF PCE-28...PC-29 TRANSMITTERS IN HAZARDOUS AREAS</b>	<b>11</b>
7.1. Exd versions in accordance with ATEX.....	11
7.2. Exd versions in accordance with IECEx .....	11
7.3. Electrostatic hazards .....	12
<b>8. INSTALLATION .....</b>	<b>12</b>
8.1. General recommendation .....	12
8.2. Installation in areas with dust explosion hazard .....	12
<b>9. ELECTRICAL CONNECTIONS.....</b>	<b>13</b>
9.1. How to connect different types of transmitters .....	13
9.2. How to connect transmitters in potentially explosive areas .....	14
9.3. Connection of transmitters in Modbus network .....	16
9.4. Grounding .....	18
<b>10. TECHNICAL DATA .....</b>	<b>18</b>
10.1. Electrical parameters.....	18
10.2. Metrological parameters.....	18
10.3. Permitted environmental conditions .....	18
10.3.1. Electromagnetic compatibility, immunity.....	18
10.3.2. Electromagnetic compatibility, emissions .....	19
10.3.3. Mechanical immunity .....	19
10.3.4. Electrical Isolation .....	19
10.3.5. Insulation strength.....	19
10.3.6. IP protection ratings .....	19
<b>11. INSPECTIONS. SPARE PARTS .....</b>	<b>20</b>
11.1. Periodic inspections .....	20
11.2. Unscheduled inspections .....	20
<b>12. SCRAPPING, DISPOSAL .....</b>	<b>20</b>
<b>13. ADDITIONAL INFORMATION.....</b>	<b>20</b>
13.1. Additional information.....	20
<b>14. HISTORY OF REVISIONS.....</b>	<b>20</b>

## LIST OF FIGURES

<b>Figure 1.</b> Pressure transmitter PCE-28, PCE-28 Ex Safety, PCE-28.Smart, PC-29A, PC-29B, PCE-28.Modbus. Dimensions.....	8
<b>Figure 2.</b> Pressure transmitter PRE-28, PRE-28 Ex Safety PRE-28.Smart, PR-29A, PR-29B, PRE-28.Modbus. Dimensions.....	8
<b>Figure 3.</b> Electrical connections of the transmitters PC(R)E-28, PC(R)E-28 Ex Safety, PC(R)E-28.Smart, PC(R)-29A, PC(R)-29B, PC(R)E-28.Modbus.....	9
<b>Figure 4.</b> PC(R)E-28, PC(R)E-28.Smart, PC(R)-29A, PC(R)-29B, PC(R)E-28.Modbus rating plate (example). ....	10
<b>Figure 5.</b> Transmitter installed in the hazard zones .....	11
<b>Figure 6.</b> Wiring diagram transmitters PCE-28, PRE-28, PCE-28 Ex Safety, PRE-28 Ex Safety.....	15
<b>Figure 7.</b> Wiring diagram transmitters PCE-28.Smart, PRE-28.Smart. ....	15
<b>Figure 8.</b> Wiring diagram transmitters PC-29A, PR-29A, PC-29B, PR-29B. ....	15
<b>Figure 9.</b> PCE-28.Modbus, PRE-28.Mobdbus electrical connection. ....	17

# 1. INTRODUCTION

The subject of manual are:

- Pressure transmitters **PCE-28**;
- Pressure transmitters **PCE-28 Ex Safety**;
- Smart pressure transmitters **PCE-28.Smart**;
- Pressure transmitters **PC-28E.Modbus**;
- Pressure transmitters **PC-29A, PC-29B**;
- Differential pressure transmitters **PRE-28**;
- Differential pressure transmitters **PRE-28 Ex Safety**;
- Smart differential pressure transmitters **PRE-28.Smart**;
- Differential pressure transmitters **PRE-28.Modbus**
- Differential pressure transmitters **PR-29A, PR-29B**

The manual contains data, information and recommendations concerning installation and use of the transmitter, as well as troubleshooting procedures.

Transmitters are designed and manufactured in accordance with the other requirements provided with the rating plate and Declarations of Conformity. Transmitters comply with EU directives:

**ATEX** **ATEX** directive, **Exd** version, certificate **KDB 18 ATEX 0077X**  
 Additional information about transmitters: **PCE-28, PRE-28, PCE-28.Smart, PRE-28.Smart, PCE-28.Modbus, PRE-28.Modbus, PCE-28 Ex Safety; PRE-28 Ex Safety and PC-29A, PC-29B, PR-29A, PR-29B** Exd versions according to **ATEX**, see p. 7.1.

**IECEX** **IECEX** system, **Exd** version, certificate **IECEX KDB 18.0005X**  
 Additional information about transmitters: **PCE-28, PRE-28, PCE-28.Smart, PRE-28.Smart, PCE-28.Modbus, PRE-28.Modbus, PCE-28 Ex Safety; PRE-28 Ex Safety and PC-29A, PC-29B, PR-29A, PR-29B** Exd versions according to **IECEX**, see p. 7.2.

**EMC** **EMC** directive.  
 Pressure and differential pressure transmitters: **PCE-28, PRE-28, PCE-28.Smart, PRE-28.Smart, PCE-28.Modbus, PRE-28.Modbus and PC-29A, PC-29B, PR-29A, PR-29B** in all versions comply with EMC directive according to: PN-EN 61326-1:2013-06.

**RoHS** **RoHS** directive.  
 Pressure and differential pressure transmitters: **PCE-28, PRE-28, PCE-28.Smart, PRE-28.Smart, PCE-28.Modbus, PRE-28.Modbus and PC-29A, PC-29B, PR-29A, PR-29B** in all versions comply with RoHS directive according to: PN-EN 50581 :2013-03.

## 2. SAFETY



- The installation and commissioning of the transmitter and any activities related to the operation should be performed only after careful examination of the contents of manual.
- Installation and maintenance should be carried out by qualified personnel having necessary authorisation to install electrical equipment and measuring instruments.
- The transmitter should be used according to its intended purpose (section 6.1) with permissible parameters.
- Before assembly or disassembly of the transmitter, one must absolutely disconnect the power source.
- Under no circumstances may the electrical system of the transmitter be repaired or otherwise handled by the user. Damage assessments and repairs may only be carried out by the manufacturer or its authorised dealer.
- Do not use damaged device. If a device is not functioning correctly, disconnect it.



- When using the device in potentially explosive areas, observe technical requirements specified in this manual and applicable local (national) regulations.

## 3. USER INFORMATION

The user receives together with the transmitter:

- a) Product Certificate, which is also a warranty card;
- b) Declaration of Conformity;
- c) Copy of the certificate (on request);
- d) User Manual ref. No. EN.IO.PCE.PRE.28.29.EXD.

Items b), c) and d) are available on the website [www.aplisens.com](http://www.aplisens.com)

## 4. TRANSPORT AND STORAGE

### 4.1. Transport

Transmitters should be transported in multi- or/and single-unit packaging. The packaging should be protected against displacement and direct weathering effect.

### 4.2. Storage

The transmitter should be stored in the original packaging, indoor rooms, free of vapours and corrosive substances, the temperature and relative humidity should not exceed the permitted conditions (see individual transmitters data sheet).

## 5. GUARANTEE

Manufacturer warrants to the conditions specified in the Product Certificate which is also a guarantee card.



Warranty is in full force under the condition of using the devices properly along with the purpose determined in the manual.

## 6. CONSTRUCTION

### 6.1. Intended use and functions

Pressure transmitters are designed to measure overpressure, vacuum pressure and absolute pressure of gases, vapours and liquids (including corrosive).

Differential pressure transmitters are designed to measure the level in closed tanks and to measure differential pressure at accumulating elements such as filters and measuring orifices.

Differential pressure transmitters with P-type tubes may operate at static pressures of up to 4 MPa.

Pressure and differential pressure transmitters may also be equipped with a number of process connectors, which make it possible to use them with different media such as dense or aggressive media and for low and high medium temperatures. Examples of process connectors are listed in point 6.2.

### 6.2. Construction and dimensions

The main units of transmitters include: measuring head in which a pressure signal is converted into an electric signal; electronic unit that converts the measuring head signal into a unified transmission signal; housing and type SGM or FL Exd electrical connector.

Made of a  $\varnothing 27$  pipe, the transmitter casing is inseparably connected to the measuring head and electric connector.

Male thread in the electrical connection allows the transmitter to be screwed into an element such as a flameproof housing, strengthened housing, etc.

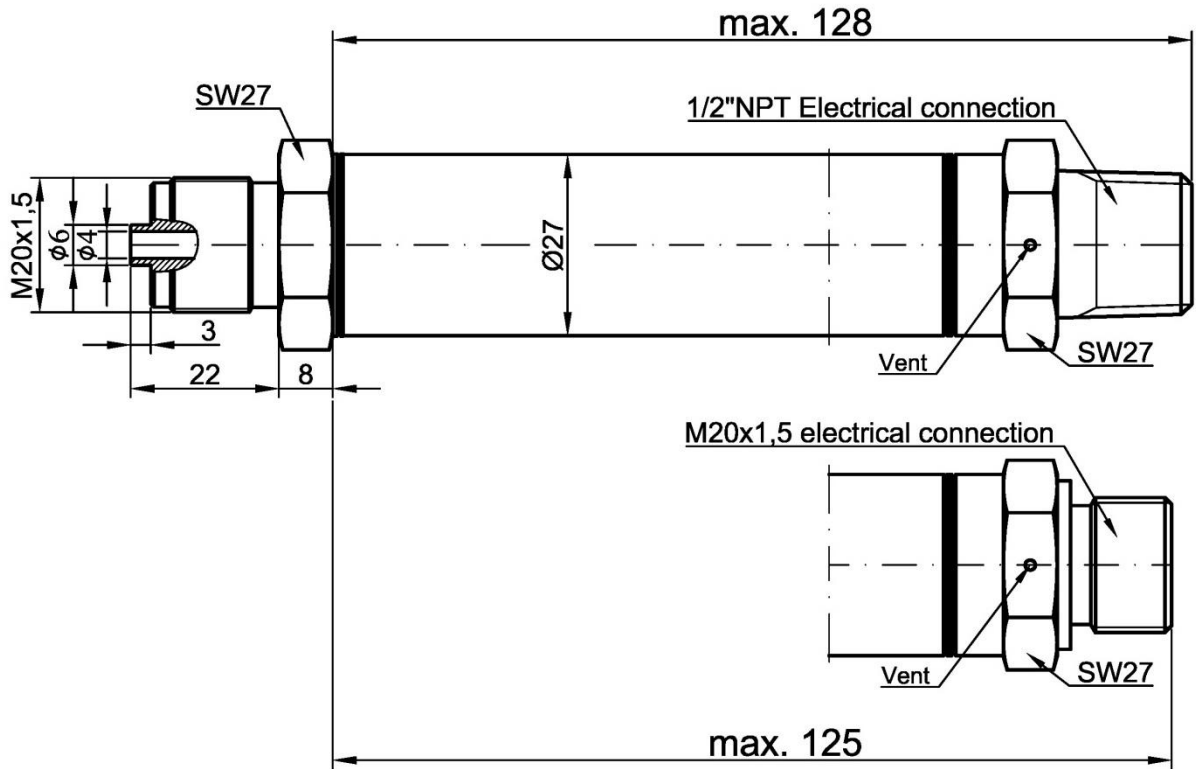

**Figure 1.** Pressure transmitter PCE-28, PCE-28 Ex Safety, PCE-28.Smart, PC-29A, PC-29B, PCE-28.Modbus. Dimensions.

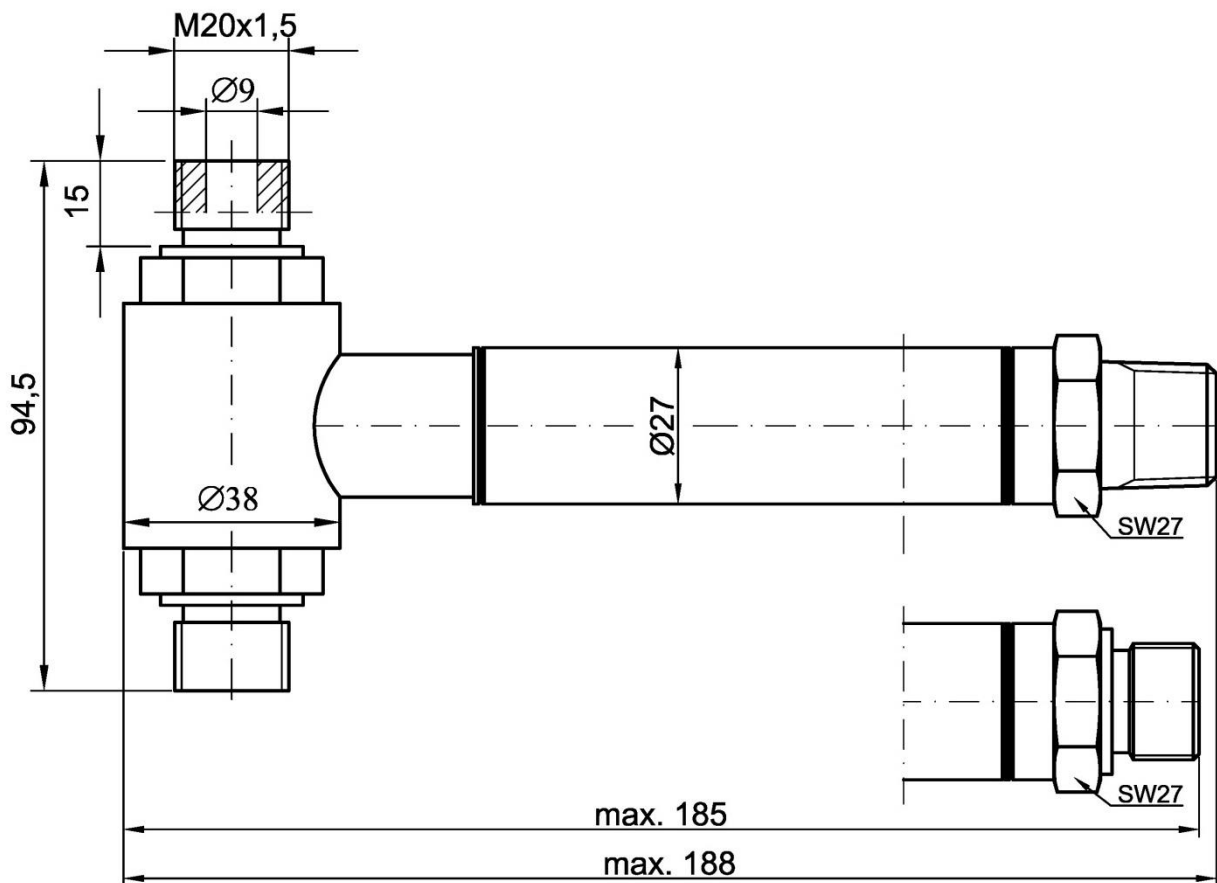

**Figure 2.** Pressure transmitter PRE-28, PRE-28 Ex Safety PRE-28.Smart, PR-29A, PR-29B, PRE-28.Modbus. Dimensions.



Transmitter can be equipped with:

- "M" process connection, thread M20x1,5;
- "P" process connection, thread M20x1,5 and Ø12 hole;
- "CM30x2" process connection, thread M30x2 with flush diaphragm;
- "G 1/2" process connection, thread G1/2" and Ø4 hole;
- "GP" process connection, thread G1/2" with flush diaphragm;
- "CG1" process connection, thread G1" with flush diaphragm;
- "RM" process connection, thread M20x1,5 with Ø4 hole and radiator;
- "RP" process connection, thread M20x1,5 with Ø12 hole and radiator;
- "G 1/4" process connection, thread G1/4" male;
- "1/2NPT" process connection, thread 1/2NPT male;
- "R 1/2" process connection, thread R ½ and Ø4 hole;
- "CG 1/2" process connection, thread G1/2" with flush diaphragm;
- "9/16-18 UNF" process connection autoclave F-250 compatible;
- "1/4NPTF" process connection, thread 1/4NPT female;
- "1/2NPTF" process connection, thread 1/2NPT female;
- Other on request.

Differential pressure transmitter measuring head can be equipped with :

- P type with M20x1,5 thread process connection;
- Diaphragm seals: see Diaphragm Seals Data Sheets;
- Other on request.

SGM type electrical connection has hermetically sealed cable with poliurethane sheath and is equipped with M20x1,5 or 1/2"NPT male thread.

FL type electrical connection has hermetically sealed wires with PVC insulation and M20x1,5 or 1/2"NPT male thread.

Electrical connection designations:

FL (M20x1,5), FL (1/2"NPT) –2, 3 or 4 according to 9.1 0,5mm<sup>2</sup> PVC insulated loose wires length: 180cm

SGM (M20x1,5), SGM (1/2"NPT) – PUR (polyurethane) cable length: 350cm

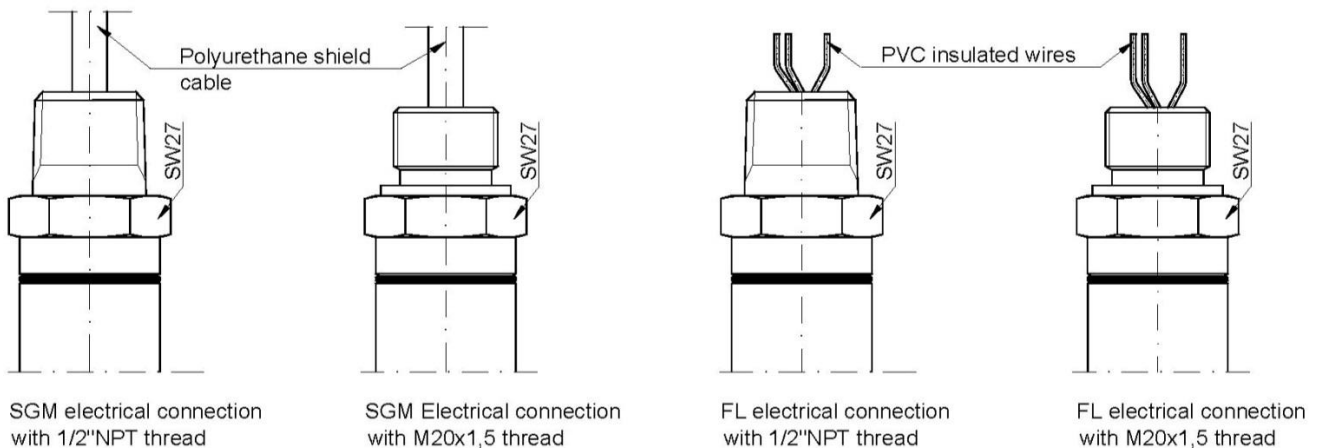
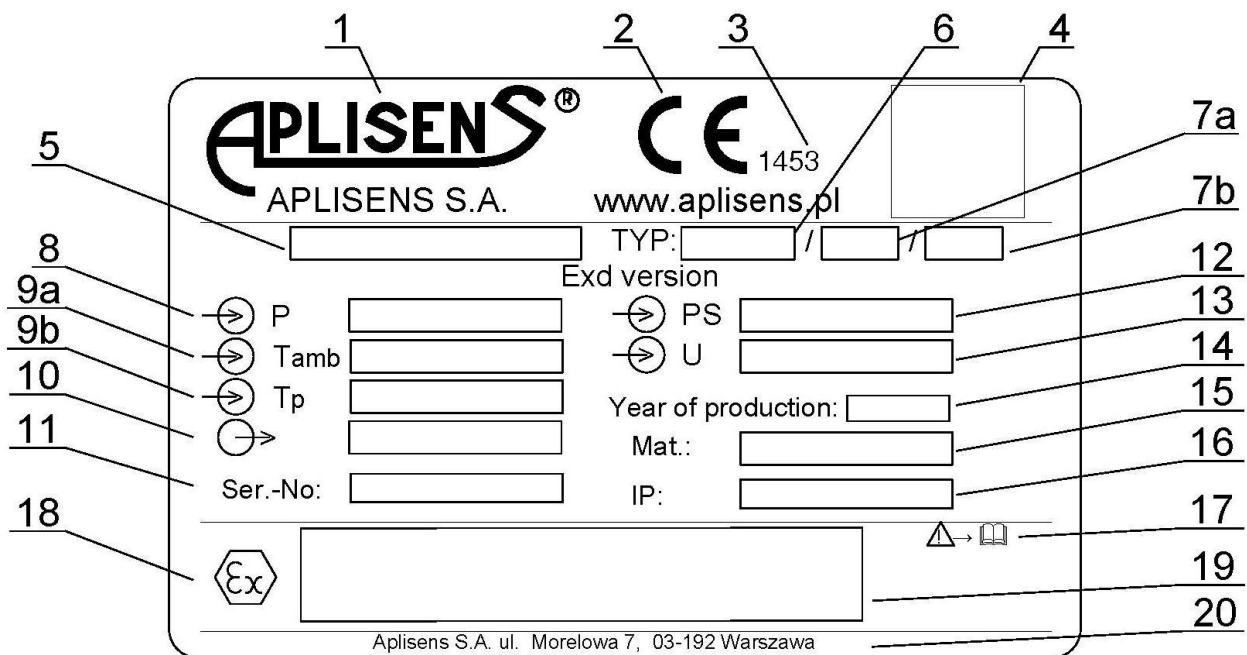

**Figure 3.** Electrical connections of the transmitters PC(R)E-28, PC(R)E-28 Ex Safety, PC(R)E-28.Smart, PC(R)-29A, PC(R)-29B, PC(R)E-28.Modbus.

### 6.3. Identification

Transmitters are provided with a rating plate containing:

1. Manufacturer name and/or logotype;
2. CE marking;
3. Number of notified body;
4. Product code;
5. Type of transmitter: „Pressure transmitter” or „Differential pressure transmitter”;
6. Transmitter type designation;
- 7a.Process connection designation;
- 7b.Electrical connection designation;
8. Measuring range;
- 9a.Permissible ambient temperature range;
- 9b.Permissible process temperature range;
10. Output signal;
11. Serial number;
12. Maximum static pressure (only for differential pressure transmitters);
13. Supply voltage;
14. Year of production;
15. Diaphragm seal material;
16. IP code;
17. Symbol „Notice”. See relevant information contained in the manual;
18. Ex mark;
19. Kind of flameproof housing designation, certificate designation;
20. Address of the manufacturer.



**Figure 4.** PC(R)E-28, PC(R)E-28.Smart, PC(R)-29A, PC(R)-29B, PC(R)E-28.Modbus rating plate (example).

## 7. USING OF PCE-28...PC-29 TRANSMITTERS IN HAZARDOUS AREAS

### 7.1. Exd versions in accordance with ATEX

The transmitters **PCE-28**, **PCE-28 Ex Safety**, **PCE-28.Smart**, **PC-29A**, **PC-29B**, **PC-28.Modbus** and pressure transmitters **PRE-28**, **PRE-28 Ex Safety**, **PRE-28.Smart**, **PR-29A**, **PR-29B**, **PRE-28.Modbus** may operate in potentially explosive areas and are marked:



**II 2G Ex db IIC T6/T5/T4 Gb**  
**II 2D Ex tb IIIC T85°C/T100°C/T120°C Db**  
**KDB 18 ATEX 0055X**

The transmitters are produced in accordance with the requirements of the following standards:

EN 60079-0:2012 + A11:2013, EN 60079-1: 2014, EN 60079-31:2014.

### 7.2. Exd versions in accordance with IECEx

The transmitters **PCE-28**, **PCE-28 Ex Safety**, **PCE-28.Smart**, **PC-29A**, **PC-29B**, **PCE-28.Modbus** and pressure transmitters **PRE-28**, **PRE-28 Ex Safety**, **PRE -28.Smart**, **PR-29A**, **PR-29B**, **PRE-28.Modbus** may operate in potentially explosive areas and are marked:

**Ex db IIC T6/T5/T4 Gb**  
**Ex tb IIIC T85°C/T100°C/T120°C Db**  
**IECEx KDB 18.0005X**

The transmitters are designed and produced in accordance with standards:  
 IEC 60079-0:2011 Ed.6, IEC 60079-1:2014 Ed.7, IEC 60079-31:2013 Ed.2

Area 1 or 2  
 Area 21 or 22

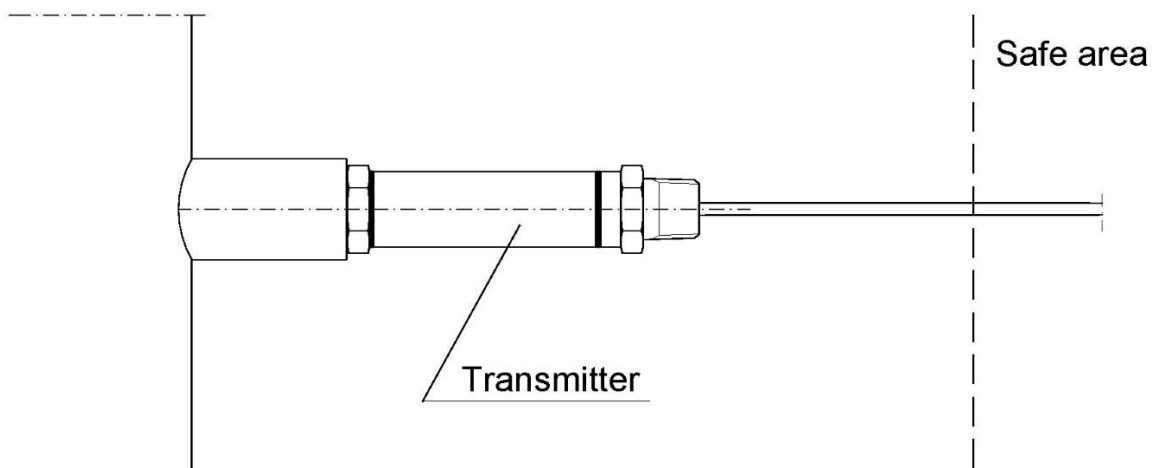

**Figure 5.** Transmitter installed in the hazard zones



Installation in potentially explosive areas is describe in p. 8.  
 Connection in potentially explosive areas is shown in p. 9.

### 7.3. Electrostatic hazards

The non-conductive layer applied onto the conductive substrate is comprised of a plastic plate. In areas with dust explosion hazard, these transmitters should be installed in such a manner as to ensure that there is no electrostatic charging, especially through contact with charged dust escaping or blown from nearby equipment.

## 8. INSTALLATION

### 8.1. General recommendation

Given their small weight and size, transmitters may be mounted directly on rigid impulse pipes.

When selecting assembly components, it may be helpful to refer to information on connection elements, adapters, sockets, valves, reduction clamps and signal tubes provided by APLISENS.

Further data may be found in the "Valves and fitting accessories" catalogue card.



While installing and using the transmitter, the diaphragm should not be exposed to damage. The transmitter diaphragm is made of stainless steel or of Hastelloy and cannot be exposed to media that may damage it.

### 8.2. Installation in areas with dust explosion hazard

The 2G (2D) category of the transmitter means that the transmitter and process connector may be installed in a hazardous area of a 1st (21) or 2nd (22) class (example is shown in Fig. 5).

Wires or cable must not be exposed to mechanical damage.

In order to protect the wires or cable against mechanical damage and to maintain protection degree IP66 and IP68 (see item 10.3.6.), screw the SGM or FL electric connection into the cover or tube using:

- for 1/2 "NPT thread - Loctite 577 sealing.
- for thread M20x1,5 - gasket.

The M20x1,5-6g and 1/2"NPT electric connection threads are made with accuracy ensuring that a flameproof Exd joint is formed.

Temperature class and maximum surface temperature depending on ambient temperature  $T_a$  and process temperature  $T_p$ :

Operating temperature range		Temperature class and maximum surface temperature	
Ambient temperature	Process temperature		
$T_a \leq 70^\circ\text{C}$	$T_p \leq 70^\circ\text{C}$	T6/T85°C	Transmitters with FL electric connection (with LgYc wires with PVC insulation)
$T_a \leq 80^\circ\text{C}$	$T_p \leq 85^\circ\text{C}$	T5/T100°C	
$T_a \leq 80^\circ\text{C}$	$T_p \leq 115^\circ\text{C}$	T4/T120°C	
$T_a \leq 65^\circ\text{C}$	$T_p \leq 75^\circ\text{C}$	T6/T85°C	Transmitters with SGM electric connection (with LiYwC11Y (1) 4x0,35c cable with polyurethane insulation)
$T_a \leq 65^\circ\text{C}$	$T_p \leq 105^\circ\text{C}$	T5/T100°C	

Low ambient temperature for pressure transmitters is -40°C,  
 Low ambient temperature for differential pressure transmitters is -25°C  
 Low ambient temperature for special versions transmitters is -50°C

**Special conditions for safe use**

- Transmitters with LiYwC11Y (1) 4x0,35c type cable (manufactured by Technokabel) (SGM electric connection), used at an ambient temperature of Ta = 65°C and process temperature 105°C, must be installed in a horizontal position in such a way that the temperature above the process connection does not exceed 100°C.
- If transmitters for Group III contain:
  - a) the nameplate made of plastic,
  - b) diaphragm seals covered by PTFE,  
 they should be installed in a way that prevents electrostatic charging, according to the instruction manual.
- If the elements made of titanium are used in the construction of the device, during installation and operation of the transmitter these elements should be protected against direct access.
- External parts made of plastic should be cleaned with a damp cloth, with the addition of antistatic fluids.
- The diaphragm should not be subject on damage during installation and exploitation of the transmitter. The transmitter diaphragm is made of stainless steel or Hastelloy alloy and must not be exposed to medium that could cause its damage.

**9. ELECTRICAL CONNECTIONS**



All connection and installation activities should be performed when the power supply and input signal are disconnected.

It is recommended to transmit signal lines through a shielded cable. Signal cables should not be led with interfering cables e.g. near large load points.

Equipment operating together with transmitters should be resistant to electromagnetic interference from the transmission line in compliance with electromagnetic compatibility requirements.

It is also beneficial to use noise filters on the primary side of transformers, power supplies for transmitters and apparatus operating with them

**9.1. How to connect different types of transmitters**

**PCE-28, PRE-28, PCE-28 Ex Safety, PRE-28 Ex Safety connection**

„FL(...)" connection	„SGM(...)" connection
Red wire (+)	Red wire (+)
Black wire (-)	Black wire (-)
	Green wire (cable shield)

### PCE-28.Smart, PRE-28.Smart connection

„FL(...)" connection	„SGM(...)" connection
Red wire (+)	Red wire (+)
Black wire (-)	Black wire (-)
	Green wire (cable shield)

### PCE-28.Modbus, PRE-28.Modbus connection

„FL(...)" connection	„SGM(...)" connection
Red wire (+)	Red wire (+)
Black wire (-)	Black wire (-)
Blue wire (VA)	Blue wire (VA)
Yellow wire (VB)	Yellow wire (VB)
	Green wire (cable shield)

### PC-29A, PR-29A, PC-29B, PR-29B connection.

„FL(...)" connection	„SGM(...)" connection
Red wire (+)	Red wire (+)
Black wire (-)	Black wire (-)
Blue wire (OUT)	Blue wire (OUT)
	Green wire (cable shield)

## 9.2. How to connect transmitters in potentially explosive areas

General principles in relation to connecting and using Exd transmitters should be consistent with the rules and standards concerning equipment with flame-proof housing as in point 7.1, including:

EN60079-14 - Electrical equipment in potentially explosive atmospheres. Part 14: Electrical installation in risk areas (other than mines).

EN60079-17 - Electrical equipment in potentially explosive atmospheres. Part 17: Inspection and operation of electrical installation in hazardous areas (other than mines).



Cables should be protected against damage by laying them in cable trays, lining pipes, cable ladders, using durable fastenings etc.



Transmitters and equipment in a transmitter measurement loop should be connected in accordance with explosion-proof standards and conditions of use in hazardous areas.

Failure to comply with explosion-proof may result in an explosion and risk to humans associated with it.

Transmitters should be powered by power supplies or other equipment that ensures that there is reinforced insulation between primary and secondary windings and which do not exceed 250V AC. It is the user who is responsible for the provision of power supply in compliance with the aforementioned requirements.



Transmitters should be supplied in accordance with the following diagrams

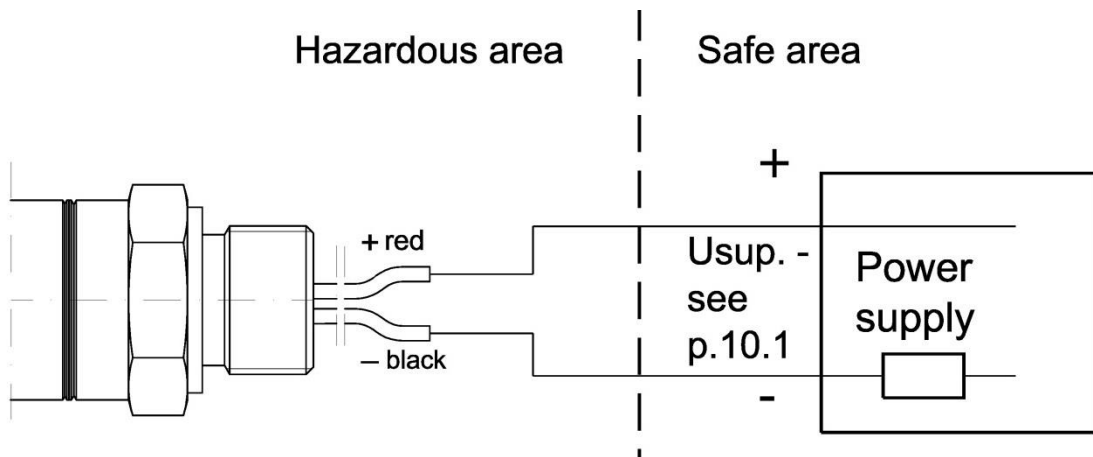

Figure 6. Wiring diagram transmitters PCE-28, PRE-28, PCE-28 Ex Safety, PRE-28 Ex Safety.

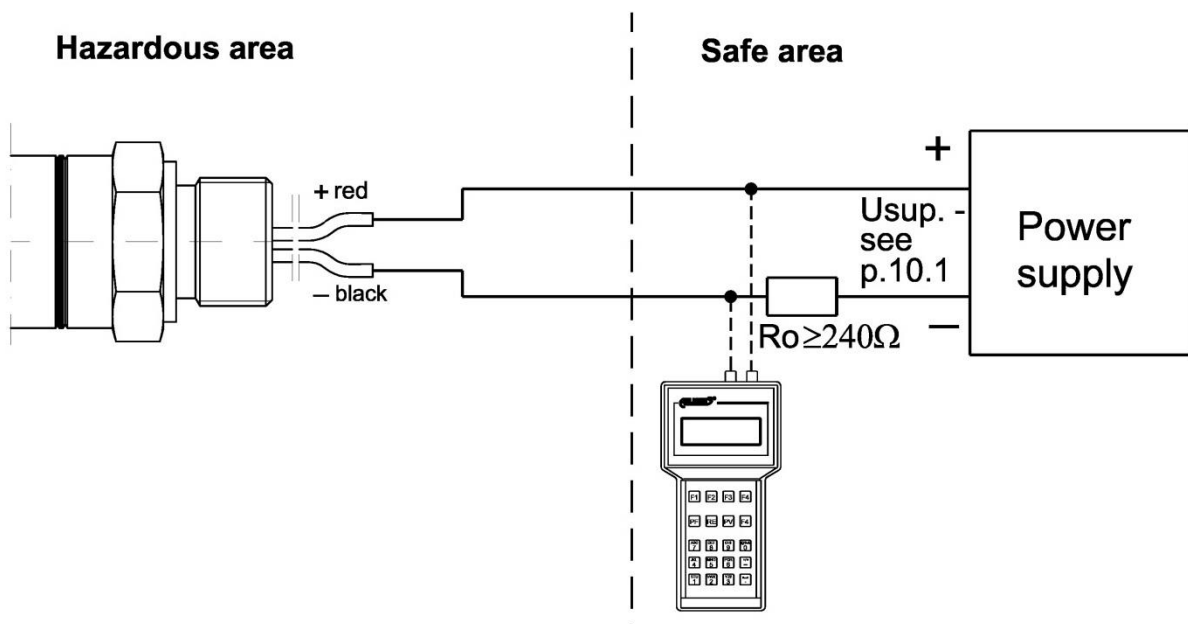

Figure 7. Wiring diagram transmitters PCE-28.Smart, PRE-28.Smart.

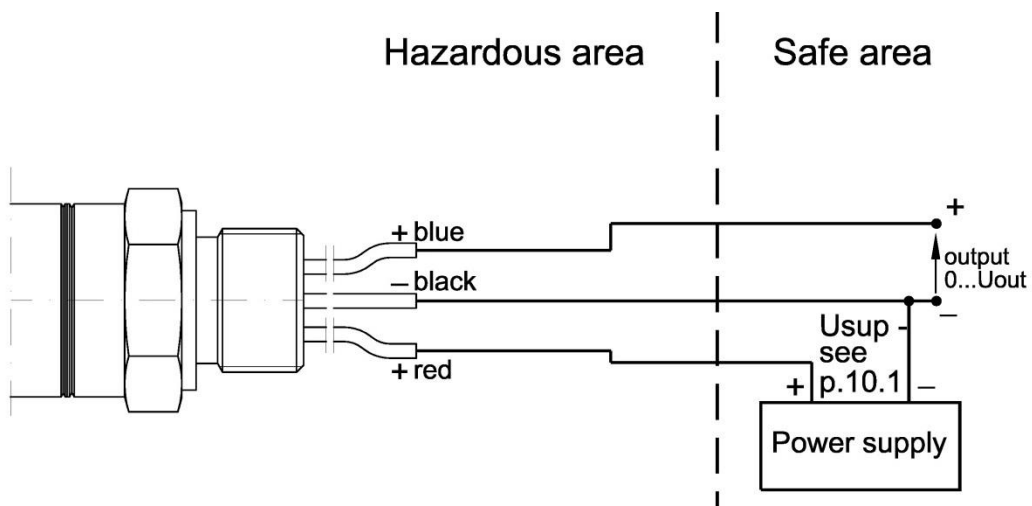

Figure 8. Wiring diagram transmitters PC-29A, PR-29A, PC-29B, PR-29B.

### **9.3 Connection of transmitters in Modbus network**

The adapting resistor 120  $\Omega$  between Digital A and B outputs should be used for all transfer rates, especially for 115200 bps (the adapting resistor is enabled by default with a jumper in Aplisens PP-Modbus junction boxes).

When using devices with MODBUS RTU output signal, it is convenient to use appropriate junction boxes. We recommend using Aplisens junction boxes designated PP-Modbus.



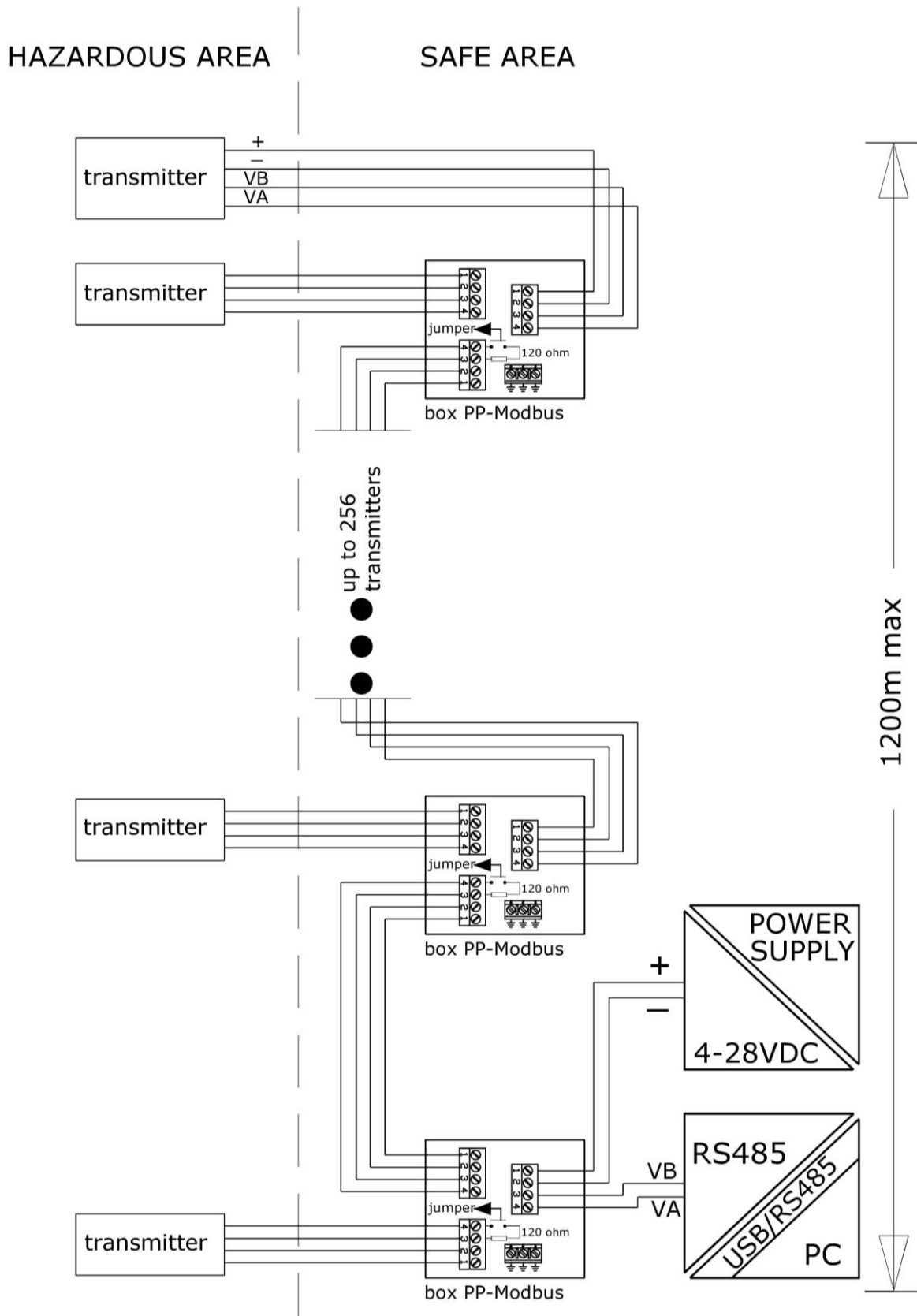

Figure 9. PCE-28.Modbus, PRE-28.Modbus electrical connection.

## 9.4 Grounding



Transmitters should be grounded in accordance with local electrical standards. It is recommended to ground transmitters by a process connector.

## 10. TECHNICAL DATA

### 10.1. Electrical parameters

Transmitter	Power supply	Signal output
PCE-28, PRE-28,	8÷30V DC	4÷20mA
PCE-28 Ex Safety, PRE-28 Ex Safety	10,5÷30V DC	4÷20mA
PCE-28.Smart, PRE-28.Smart.	7,5÷30V DC	4÷20mA + Hart
PCE-28.Modbus, PRE-28.Modbus.	4÷28V DC	MODBUS RTU
PC-29A, PR-29A	7,5...16V DC	0,5...4,5V
	8...16V DC	1...5V
	13...16V DC	0...5V
PC-29B, PR-29B	3,3...5,6V DC	0...10V
	3,5...5,6V DC	0...2V
	4...5,6V DC	0...2,5V
	4,3...5,6V DC	0...3V
	3,3...5,6V DC	0...3,3V
	3,5...5,6V DC	0,4...2V

Power supply  $\leq 1W$

For other parameters see 8.2. and transmitter's data sheet.

### 10.2. Metrological parameters

See individual transmitter's data sheet.

### 10.3. Permitted environmental conditions

See 8.2. and individual transmitter's data sheet.

#### 10.3.1. Electromagnetic compatibility, immunity

Assessment acc. to PN-EN 61326-1 for industrial applications:

*Electrostatic discharges (ESD):*

PN-EN 61000-4-2

level S3; contact  $\pm 6kV$ ; air  $\pm 8kV$ ; criterion B;

*Conducted interferences induced by fields with radio frequency:*

PN-EN 61000-4-6

0,15...80MHz, 3V; Criterion A;

*Electromagnetic fields (radiated interferences):*

PN-EN 61000-4-3

80...2000MHz - 10V/m; ...2700MHz - 1V/m; Criterion A;

*Fast electrical transient conditions (Burst):*

PN-EN 61000-4-4

± 2kV supply lines; ± 1kV signal lines; Criterion B;

*Surges:*

PN-EN 61000-4-5

± 0,5kV (±1kV) signal lines - enclosure; ± 1kV (±2kV) supply lines - enclosure; Criterion B.

### **10.3.2. Electromagnetic compatibility, emissions**

Measurements acc. to CISPR 16-1, CISPR 16-2, class B;

Distance of antenna 3m, quasi-peak measurements:

*Radiation:*

0,15...30MHz; 80-52dB $\mu$ V/m;

30...2000MHz; <54dB $\mu$ V/m;

*Inductions:*

0,01...0,15MHz; 96-50dB $\mu$ V/m;

0,15...0,35MHz; 60-50dB $\mu$ V/m;

0,35...30MHz; <50dB $\mu$ V/m.

### **10.3.3. Mechanical immunity**

*Shocks:*

PN-EN 60068-2-27, 31

50g/11ms

*Sinusoidal vibrations:*

PN-EN 60068-2-6, Fc test;

to 1,6mm; 2...25Hz;

to 4g for 25...100Hz.

### **10.3.4. Electrical Isolation**

>100M $\Omega$  @110V DC

### **10.3.5. Insulation strength**

75V AC (110V DC), 1 min

### **10.3.6. IP protection ratings**

Acc. PN-EN 60529:2003

- IP68 – for transmitters designed to measurement of underpressure or absolute pressure.

- IP66 – for transmitters designed to measurement of pressure.

## 11. INSPECTIONS. SPARE PARTS

### 11.1. Periodic inspections

During inspection, the connectors should be checked for loose connections and leaks, the electrical connectors should be checked with regard to tightness and the state of the housing, gaskets, cable glands, and the diaphragm seals should be checked for tarnishing and corrosion. Readability of the tag should also be checked.

### 11.2. Unscheduled inspections

If the transmitter is installed in a location where it could be subjected to mechanical damage, electrical surges or malfunction is found - inspect it as needed.

In case of lack of signal in the transmission line or its incorrect value, check the state of the cable, of the connection on terminals, etc. Determine whether the values of the supply voltage and load resistance are correct. If the communicator is connected to the transmitter power supply line, an indication of a fault line may be the message "No response" or "Check connection". If the line is in order, check operation of the transmitter.

## 12. SCRAPPING, DISPOSAL



Waste or damaged transmitters should be dismantled and disposed of in accordance with Directive (2012/19/EU) on waste electrical and electronic equipment (WEEE) or returned to the manufacturer.

## 13. ADDITIONAL INFORMATION

### 13.1. Additional information

The manufacturer reserves the right to make constructional and technological changes which do not lower the quality of the transmitters.

## 14. HISTORY OF REVISIONS

Revision No.	Document revision	Description of changes
5	04.A.005/2020.09	Modbus connection description added, change of figure 9. History of revisions added. Prepared by DBFD.

