



USER'S MANUAL



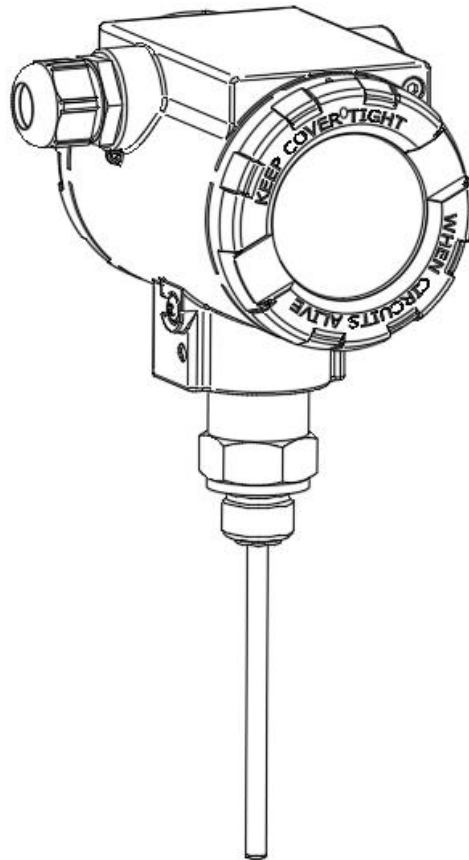

TEMPERATURE TRANSMITTER

APT-2000ALW

Version in accordance with EN 12405-1:2018 Standard (MID)



Symbols used

Symbol	Description
	Warning to proceed strictly in accordance with the information contained in the documentation in order to ensure the safety and full functionality of the device.
	Information particularly useful during installation and operation of the device.
	Information particularly useful during installation and operation of an Ex type device.
	Information on disposal of used equipment.

BASIC REQUIREMENTS AND SAFE USE



The manufacturer will not be liable for damage resulting from incorrect installation, failure to maintain a suitable technical condition of the device or use of the device other than for its intended purpose.

Installation should be carried out by qualified staff having the required authorizations to install electrical and I&C equipment. The installer is responsible for performing the installation in accordance with manual as well as with the electromagnetic compatibility and safety regulations and standards applicable to the type of installation.

In systems with I&C equipment, in case of leakage, there is a danger to staff due to the medium under pressure. All safety and protection requirements must be observed during installation, operation and inspections.

If a malfunction occurs, the device should be disconnected and handed over to the manufacturer for repair.



In order to minimize the risk of malfunction and associated risks to staff, the device is not to be installed or used in particularly unfavourable conditions, where the following hazards occur:

- possible mechanical impacts, excessive shocks and vibration;
- excessive temperature fluctuation;
- water vapour condensation, dusting, icing.

Changes made to the manufacturing of products may be introduced before the paper version of the manual is updated. The up-to-date manuals are available on the manufacturer's website: www.aplisens.com.

TABLE OF CONTENTS

1. INTRODUCTION	5
1.1. Purpose of the document.....	5
1.2. Trademarks	5
1.3. Definitions and abbreviations	5
1.4. Transmitter set range.....	6
2. SAFETY	6
3. TRANSPORT AND STORAGE	7
3.1. Delivery check	7
3.2. Transport	7
3.3. Storage.....	7
4. GUARANTEE.....	7
5. IDENTIFICATION	8
5.1. Manufacturer's address	8
5.2. Transmitter identification.....	8
5.3. CE mark, declaration of conformity	8
6. INSTALLATION	8
6.1. General recommendations.....	8
7. ELECTRICAL CONNECTION	9
7.1. Cable connection to transmitter terminals	9
7.1.1. Cable connection	9
7.1.2. Connection of transmitter with the option of using local HART communication.....	9
7.2. Transmitter power supply.....	11
7.2.1. Transmitter supply voltage	11
7.2.2. Uninterruptible current measurement in 4 ... 20 mA current loop	11
7.2.3. Specifications of electrical switching terminals	11
7.2.4. Cabling specification	11
7.2.5. Resistance load in power supply line.....	12
7.2.6. Shielding, equipotential bonding.....	12
7.3. Overvoltage protection.....	12
7.4. Final inspection of cabling.....	12
8. START-UP	13
8.1. Alarm configuration.....	13
8.2. Configuration of operating mode	13
8.3. Sealing of the transmitters	14
8.4. Temperature measurements.....	14
9. OPERATION	16
9.1. Local LCD display	16
9.2. Local buttons	17
9.3. Local configuration of setpoints.....	17
9.4. Navigation in local setpoints MENU	17
9.5. Acceptance of local setpoints.....	17
9.6. Structure of local setpoints MENU	18
9.7. Remote configuration of setpoints (HART).....	19
9.7.1. Compatible devices.....	19
9.7.2. Compatible configuration software	20
9.7.3. Local HART communication jumper	20
10. EXPLOSIONPROOF PARAMETERS	20
10.1. Transmitters with Exd protection	20
10.2. Transmitter explosion-proof marking.....	20
10.3. Category of transmitter and hazard zones	20
10.4. Power supply and exploitation of transmitter	20
10.5. Measurement of operating temperature of transmitter.....	20

10.6. Determination of the temperature class T* of the transmitter for gas	21
10.7. List of cable glands and plug replacements	22
10.8. Specific conditions of use	22
10.9. Transmitters with Exi protection.....	23
10.10. Transmitter explosion-proof marking.....	23
10.11. Ui, li, Pi supply parameters and temperature classes.....	24
11. MAINTENANCE.....	25
11.1. Periodic inspections	25
11.2. Non-periodic inspections	25
11.3. Cleaning/washing.....	25
11.4. Spare parts	25
11.5. Repair	25
11.6. Returns	25
12. SCRAPPING, DISPOSAL.....	25
13. HISTORY OF REVISIONS.....	25

LIST OF DRAWINGS

Figure 1. Set range and measurement limits	6
Figure 2. Transmitter nameplate	8
Figure 3. Electrical connection to transmitter.....	9
Figure 4. Electrical connection 4 ... 20 mA of HART to transmitter in Exd version.....	10
Figure 5. Electrical connection 4 ... 20 mA of HART to transmitter in Exi version.....	10
Figure 6. Example of the transmitter side covers sealing.....	14
Figure 7. Rotation of the housing, change of display position and access to buttons.....	16
Figure 8. Display information fields.....	16
Figure 9. Structure of local setpoints menu of the transmitter	18
Figure 10. Mounting the transmitter in zones.....	21
Figure 11. Flameproof joints.....	23
Figure 12. Mounting the transmitter in zones.....	23
Figure 13. The principle of feeding from a source with a linear characteristic	24
Figure 14. The principle of feeding from a source with a trapezoidal characteristic	24

LIST OF TABLES

Table 1. Definitions and abbreviations	5
Table 2. Permissible transmitter supply voltages	11
Table 3. Example of recommended types of cable	11
Table 4. Alarm currents of transmitters	13
Table 5. Explanation of menu items.....	19
Table 6. List of cable glands	22
Table 7. List of blank plug replacements.....	22

1. INTRODUCTION

1.1. Purpose of the document

The subject of manual are the installation and exploitation data of the APT-2000ALW MID smart temperature transmitters with direct resistive sensor Pt100, designed to work in user's thermowell. Transmitters APT-2000ALW MID meet the requirements of the EN12405-1:2018 Standard, harmonized to Directive 2014/32/EU (MID) and are used for type 2 of gas conversion device. In the following, they will be referred to as transmitters. The manual applies to intrinsically safe (Exi) and the flameproof (Exd) versions.

Within the scope of the MID Directive, transmitters are intended for use in volume gas converters 2 type, equipped with an electric power backup source (battery, UPS) for 1 and 2 family gas fuels in accordance with EN 437 Standard.



The Exi and Exd transmitter parameters are presented in the section → [10. EXPLOSIONPROOF PARAMETERS](#)

The manual contains data, tips and general recommendations for safe installation and operation of the transmitters, as well as troubleshooting in case of possible failure.



The use of the equipment in hazardous zones without appropriate approvals is forbidden.

1.2. Trademarks

HART® is a registered trademark of FieldComm Group.

Windows® is a registered trademark of Microsoft Corporation.

Google Play® is a service registered and managed by Google® Inc.

1.3. Definitions and abbreviations

Table 1. Definitions and abbreviations

Item no.	Abbr.	Meaning
1	LRV	"Lower Range Value" – the value of the set range expressed in physical units corresponding to the current of 4,000 mA, i.e. 0% of the output setpoint. Exceeding the LRV limit, with the MID blockade on, makes the generation of alarm signals by the transmitter, and on the main display the undEr inscription will be showed.
2	URV	"Upper Range Value" – the value of the set range expressed in physical units corresponding to the current of 20,000 mA, i.e. 100% of the output setpoint. Exceeding the URV limit, with the MID blockade on, makes the generation of alarm signals by the transmitter, and on the main display the ouEr inscription will be showed.
3	LRL LSL	"Lower Range Limit" or "Lower Sensor Limit" – lower limit of set range expressed in physical units. Value (URL-LRL) or (USL-LSL) is referred to as the base transmitter range.
4	URL USL	"Upper Range Limit" or "Upper Sensor Limit" – upper limit of set range expressed in physical units. Value (URL-LRL) or (USL-LSL) is referred to as the base transmitter range.
5	LPL	"Lower Processing Limit" – lower limit of digital processing of measured value. The transmitter digitally processes a measurement up to 50% of the base range width below the lower limit of set range LRL (LSL) .
6	UPL	"Upper Processing Limit" – upper limit of digital processing of measured value. The transmitter digitally processes a measurement up to 50% of the base range width above the upper limit of set range URL (USL) .
7	LSAL	"Lower Saturation Limit" – lower limit of the A/D transmitter processing range. The lower limit of the A/D transmitter saturation is on the temperature scale below the LPL point and is associated with the minimum temperature, at which the analogue-digital temperature measurement transmitter reaches the lower limit of the processing capacity.
8	USAL	"Upper Saturation Limit" – upper limit of the A/D transmitter processing range. The upper limit saturation point of A/D transmitter is on the temperature scale above the UPL point and is associated with the maximum temperature, at which the analogue-digital temperature measurement transmitter reaches the upper limit of the processing capacity.
9	AL_L	Low current alarm.
10	AL_H	High current alarm.
11	I_AL	The alarm current set by the transmitter controller in the current loop.

1.4. Transmitter set range

The figure below shows the transmitter set range and limits related to allowable set range, digital processing range and saturation limits of A/D transducer of temperature measurement. As standard, values of 4 mA/20 mA currents are assigned to LRV/URV points. In order to obtain reverse characteristics, it is possible to reverse the assignment so that the LRV/URV points are assigned to 20 mA/4 mA currents.

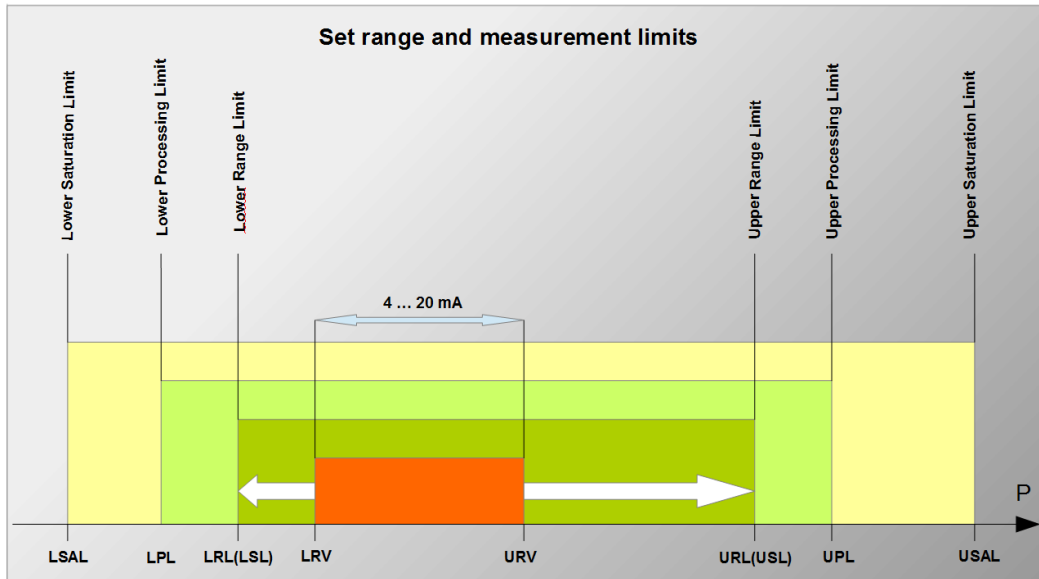

Figure 1. Set range and measurement limits

2. SAFETY



- The installation and start-up of the device and any activities related to operation shall be carried out after thorough examination of the contents of user's manual and the instructions related thereto.
- Installation and maintenance should be carried out by qualified staff having the required authorizations to install electrical and measuring devices.
- The device shall be used according to its intended purpose in line with the permissible parameters specified on the nameplate (→ 5.2. Transmitter identification).
- The protection elements used by the manufacturer to ensure transmitter safety may be less effective if the device is operated in a manner not consistent with its intended purpose.
- Before installing or disassembling the device, it is absolutely necessary to disconnect it from the power source.
- No repairs or alterations to the transmitter electronic system are permitted. Assessment of damages and possible repair may only be performed by the manufacturer or authorized representative.
- Do not use instruments if damaged. In case of malfunction, the device must be put out of operation.

3. TRANSPORT AND STORAGE

3.1. Delivery check

After receiving the delivery of the equipment, it is necessary to:

- make sure that the packaging and its contents were not damaged during transport;
- check the completeness and correctness of the received order, and make sure no parts are missing.

3.2. Transport

Transport of transmitters shall be carried out with the use of covered means of transport, in original packages with process connection provided with protection. The packaging shall be protected against movement and direct impact of atmospheric factors.

3.3. Storage

Transmitters shall be stored in a factory packaging, in a room without vapours and aggressive substances, protected against mechanical impact.

Allowable range of storage temperature:

-40 ... 80 °C (-40 ... 176 °F).

4. GUARANTEE

General terms and conditions of guarantee are available on the manufacturer's website:

www.aplisens.com/ogolne_warunki_gwarancji.



The guarantee shall be repealed if the device is used against its intended use, or failure to comply with user's manual or interference with the structure of the device.

5. IDENTIFICATION

5.1. Manufacturer's address

APLISENS S.A.
03-192 Warsaw
Morelowa 7 St.
Poland

5.2. Transmitter identification

The transmitter is labelled with rating plates with data as shown below.

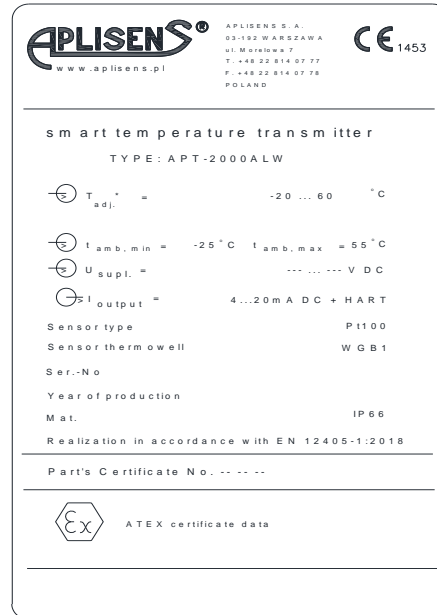

Figure 2. Transmitter nameplate

*) transmitters are offered in one of measuring ranges below:

-20 ... 40 °C

·
·
·

-20 ... 60 °C

5.3. CE mark, declaration of conformity

The device has been designed to meet the highest safety standards, has been tested and has left the factory in a condition that is safe for operation. The device complies with the applicable standards and regulations listed in the EU Declaration of Conformity and has CE marking on nameplate.

6. INSTALLATION

6.1. General recommendations



Temperature transmitter APT-2000ALW can be mounted in any position but always in thermowell. The housing of the transmitter should be protected against hot air streams by appropriate location of the transmitter or by installing thermal screens so that the transmitter does not heat up to a temperature higher than the permissible one. The transmitter housing allows for wall and pipe mounting. For this purpose, use the AL handle by Aplisens S.A.

7. ELECTRICAL CONNECTION

7.1. Cable connection to transmitter terminals



All connection and installation operations shall be performed with disconnected supply voltage and other external voltages, if used.



Failure to provide proper connection of the transmitter may result in danger. Risk of electric shock and/or ignition in potentially explosive atmospheres.

7.1.1. Cable connection

In order to perform correct connection of the cables, the following steps shall be performed:

- Disconnect power supply of the supply cable line before connecting the transmitter cabling.
- Unscrew the rear cover of the transmitter body to access the power connector.
- Pull the cable through the cable gland.
- Connect the transmitter according to the figure below, paying attention to the correct tightening of the bolts fixing the conductor core to the terminal.
- Check the correct fixing of the hart local communication jumper.
- Tighten the rear cover of the transmitter body.
- Leaving a small clearance of the cable inside the body, tighten the gland nut so that the gland seal is clamped on the power cable.

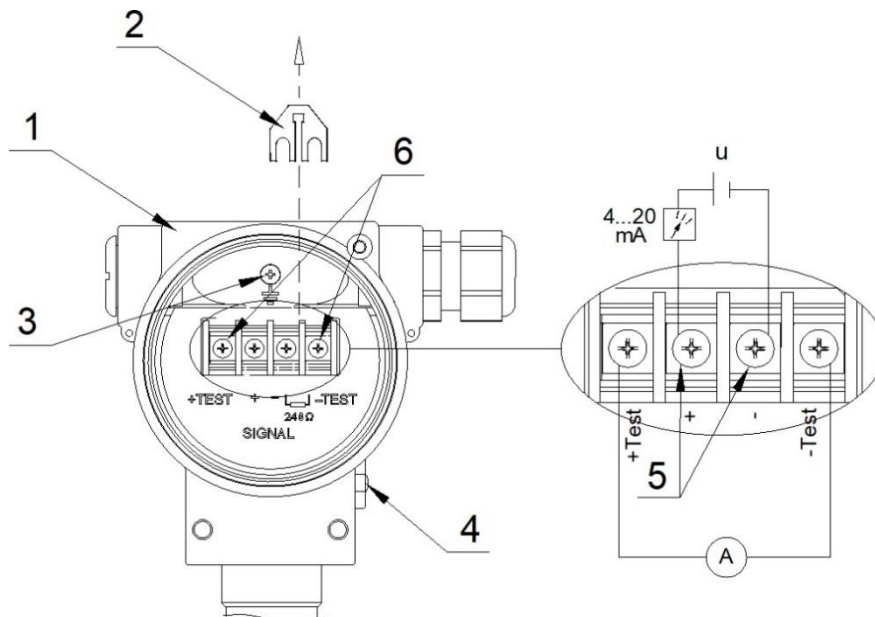

Figure 3. Electrical connection to transmitter

1. Housing.
2. Jumper for local HART communication.
3. Internal ground terminal.
4. External ground terminal.
5. Transmitter power terminals, 4 ... 20 mA current loop.
6. Ammeter connection terminals for uninterruptible current measurement in current loop(optional).



In hazardous zone, do not unscrew the housing covers after connecting the Exd flame-proof transmitter to the power source.

7.1.2. Connection of transmitter with the option of using local HART communication

The transmitter allows to use the local HART communication. To do this you can use a HART communicator or HART modem connected to a computer or a smartphone.

In order to establish the local communication, it is necessary to:

- remove HART communication jumper (item 2);
- connect the communicator or modem to electrical terminals (item 5).



Opening of the HART jumper results in applying resistance of 240 Ω in series in line 4 ... 20 mA. This resistance reduces voltage on transmitter supply terminals by approximately 5 V DC for maximum current that can be set by the transmitter. **To avoid the supply voltage deficit on the transmitter terminals, the HART jumper must be dismantled only for the time of performing the HART local communication.**

Connection diagram of the communicator or modem to transmitter power supply and measurement system is presented below:

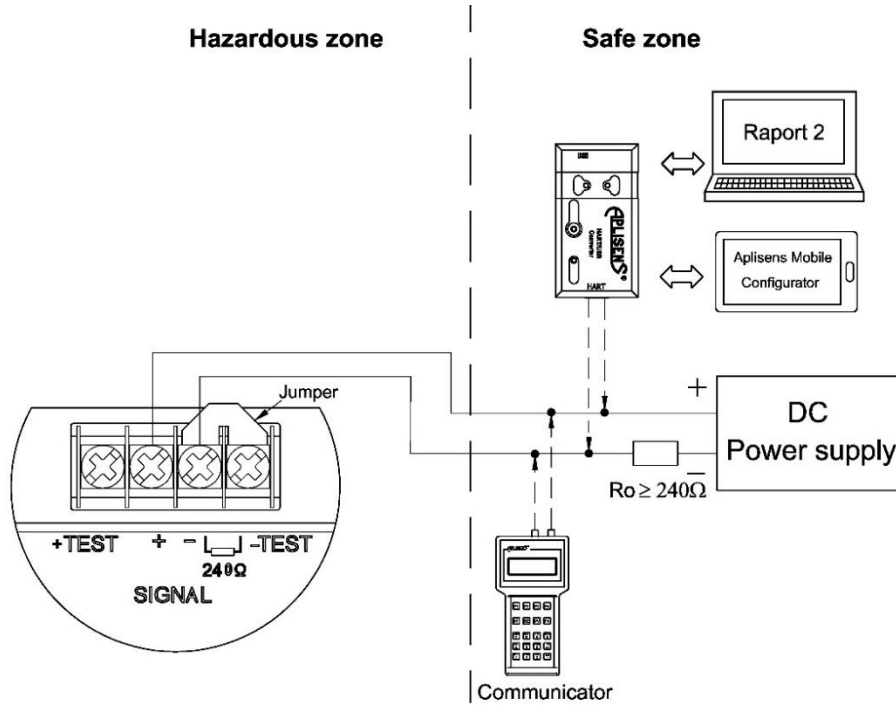

Figure 4. Electrical connection 4 ... 20 mA of HART to transmitter in Exd version

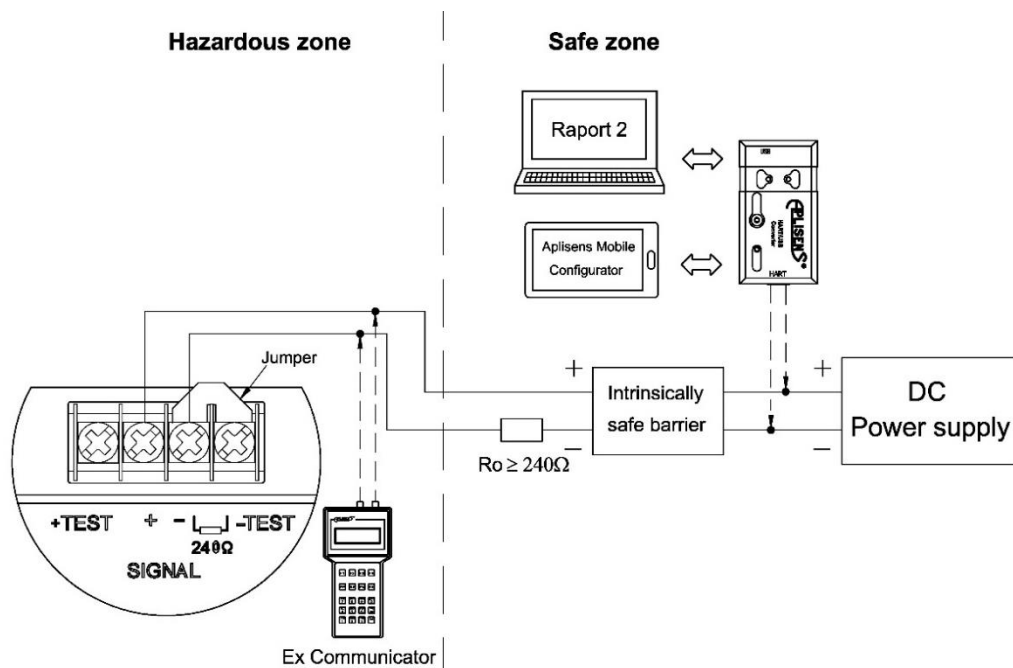

Figure 5. Electrical connection 4 ... 20 mA of HART to transmitter in Exi version



It is mandatory to read section → **10. EXPLOSIONPROOF PARAMETERS**, containing important information related to the installation of intrinsically safe and flameproof versions of the transmitter.

The converter HART/USB Aplisens may also be operated using **Aplisens Mobile Configurator** installed on smartphones with Android system and connected using wireless communication.

The software is available on Google Play®:

<https://play.google.com/store/apps/details?id=com.aplisens.mobile.amc>.

7.2. Transmitter power supply

7.2.1. Transmitter supply voltage



Power cables may be live.
There is a risk of electric shock and/or explosion.



Installation of the transmitter in explosion-risk atmospheres must comply with national standards and regulations.

All explosion protection data is given in section → **10. EXPLOSIONPROOF PARAMETERS**.

Table 2. Permissible transmitter supply voltages

Version	Minimum supply voltage	Maximum supply voltage
Exi	13,5 V DC	30 V DC
Exd	13,5 V DC*	45 V DC

* Minimum supply voltage with backlight off. Switching on the backlight increases the minimum supply voltage by 3V. The backlight is switched off by default.

7.2.2. Uninterruptible current measurement in 4 ... 20 mA current loop

The transmitter is capable of continuous current measurement in the current loop using an ammeter. In order to maintain the current measurement error below 0,05%, the internal resistance of the ammeter shall be less than 10 Ω.

Ammeter connection diagram – see: → **Figure 3. Electrical connection to transmitter**.

7.2.3. Specifications of electrical switching terminals

Internal electrical switching terminals are suitable for conductors with the cross-section from 0,5 to 2,5 mm². The internal and external electrical ground terminal of the body are suitable for conductors with cross-section from od 0,5 to 5 mm².

7.2.4. Cabling specification

Aplisens S.A. recommends using two-wire screened twisted pair cable. The outer diameter of the cable shell from 5 to 9 mm is recommended.

Exemplary cable types are presented in the table below.

Table 3. Example of recommended types of cable

Type	Producer	
	Technokabel	LAPPKABEL
shielded	IB-YSLY 2x0.75	ÖLFLEX® EB 2X1 (art. No. 0012440)
unshielded	IB-YSLCY 2x0.75	ÖLFLEX® EB CY 2X1 (art. No. 0012650)

7.2.5. Resistance load in power supply line

The power line resistance, power source resistance and other additional serial resistances increase the voltage drops between the power source and the transmitter terminals. The maximum current of Exd or Exi transmitters under normal operation conditions is defined as $I_{max} = 20,500$ mA, in the high alarm state, the I_{max} current rises to at least 21,5 mA.

The maximum resistance value in the power circuit (along with the power cables resistance) is defined by the formula:

$$R_{L_MAX} = \frac{(U - U_{min}) [V]}{0,0215 [A]}$$

where:

R_{L_MAX} – maximum power supply line resistance [Ω],

U – voltage at the supply terminals of the 4 ... 20 mA current loop [V],

U_{min} – minimum supply voltage of transmitter [V] ([→ Table 2. Permissible transmitter supply voltages](#)).

7.2.6. Shielding, equipotential bonding

When using a cable in the screen, connect the screen on one side. The best option is to connect it in power supply and measurement installation cabinet.

7.3. Overvoltage protection

Transmitters comply with EMC standards in terms of emission and immunity for products used in industrial environments.

7.4. Final inspection of cabling

After completing the electrical installation of the transmitter it is necessary to check the following:

- Does the supply voltage measured at the transmitter terminals at maximum set current match the range of supply voltage specified on the transmitter nameplate?
- Is the transmitter connected according to the information given in section [→ 7.1. Cable connection to transmitter terminals](#)?
- Are all the screws tightened?
- Are the transmitter covers tightened?
- Are the cable gland and the gland plug tightened?

8. START-UP

As standard, the transmitter is adjusted to a set range equal to the base range, unless a specific set range is provided in the order. The base range and the basic unit of the transmitter can be read out from its nameplate (→ 5.2. Transmitter identification).



Use the transmitter within the allowable temperature limits. Risk of injury due to component breakage after exceeding the maximum permitted operating temperature.

8.1. Alarm configuration

Transmitters has a developed internal diagnostics, which monitors the work of their electronic circuits, process and environmental parameters.

The user has an option of enabling/disabling the current alarms. Current alarms are disabled by default. The table below shows value of alarm currents.

Table 4. Alarm currents of transmitters

Type of alarm	Value of alarm current [mA]
NORMAL LOW	3,75
NORMAL HIGH	21,6
NAMUR LOW	3,6
NAMUR HIGH	21,0

8.2. Configuration of operating mode

Before starting the work with the transmitter, the following parameters must be configured:

- basic unit of transmitter;
- the beginning of the set range LRV;
- the end of the set range URV;
- damping time constant;
- NORMAL/NAMUR analogue output operation mode;
- alarm mode, high or low alarm;
- transmitter tag (TAG/LONG_TAG);
- LCD display configuration parameters;
- setting of the settings change lock password.

Once the transmitter parameters have been entered and it has been reset at the workstation, it is required to:

- Secure the device against the possibility of making changes in the local setpoint change MENU.
- Set your own password different from default password of “00000000”. The new password may consist of any combination of 8 hexadecimal characters 0 ... 9, A ... F. Store the password in a safe place. If the password is lost, its restoration or resetting to factory settings may only be performed by the manufacturer.
- Activate the setpoint change lock to secure the transmitter against accidental/unauthorized change of parameters.

Operations described above can be done via HART communication.



For Exd type transmitters, opening the housing cover in the hazardous zone in order to use the local setpoint change MENU is forbidden.

8.3. Sealing of the transmitters

The transmitters are sealed according to the regulations in the place/country of using. The manufacturer seals the side covers and the sensor as well as the nameplate, if it is made of metal. The sealing method of the transmitter by the manufacturer is shown at figure below.

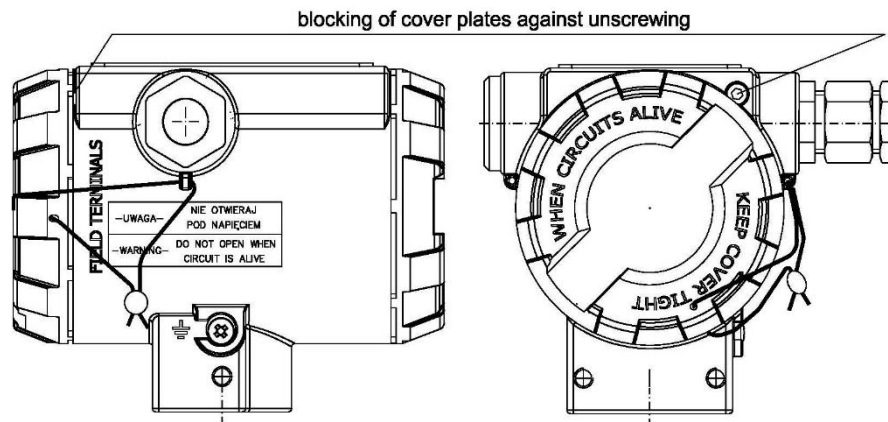

Figure 6. Example of the transmitter side covers sealing



Protection against changes in the settings in the transmitter can be done as follows:

- systemically, activated by a configuration program (Raport 2) and protected by password, with „spec lock” disabled;
- done with local buttons on the transmitter with a local menu (command MID_WP) with „spec lock” disabled.



As a standard, the manufacturer turns on the “spec lock” or, in agreement with the ordering party, the transmitter may be unblocked.



Local buttons, enabling the activation of the “spec lock”, are secured with side cover which could be sealed. With the “spec lock” on, it is possible to change only some of the transmitter parameters, i.e. the HART address of the transmitter and the time constant, and transmitter identification entries related to its place of work can be made, e.g. TAG.

8.4. Temperature measurements

The transmitter version in accordance with the EN 12405-1: 2018 standard is designed to measure temperatures of gases, vapors and liquids. The metrological parameters of the transmitter are presented below.

Measurement ranges **-20 ... 60 °C ***
 .
 .
-20 ... 40 °C

*) The transmitter measurement range is setting by the manufacturer. For range **-20 ... 60 °C** it is possible to lower the upper limit of the range to 40°C. A lower measurement range can be set by manufacturer at the user's request, or can be changed by the user after removing the lock.

Maximum permissible error (according to EN 12405-1:2018)

(calculated in relation to the measured value)

- | | |
|--|----------------|
| – at the rated temperature range: (-25 ÷ 55 °C) | ≤ 0,2 % |
| – at reference conditions | ≤ 0,1 % |
| – long-term stability / 5 years | ≤ 0,2 % |

Cover type of temperature sensor

WGB1

Enclosure Ingress Protection

IP 66



For the clearing needs, in accordance with Directive 2014/32/EU, should be used one of the two metrological checked transmitter output signals: digital HART signal rev 5.1 or analogue current signal.

Other parameters

Medium temperature range	-20 ÷ 60 °C
Ambient temperature range	-25 ÷ 55 °C
Relative humidity	10 ÷ 98 % with condensation
Error due to supply voltage changes	0,002 %(FSO) / 1V
Thermal error	< ± 0,05 %(FSO) / 10°C
Output updating time (period of calculation cycle)	150 ms
Dumping	0 ... 60 s
Sensor length	min. 150 mm
Length of the connection cable	max. 1500 m

Transmitters environmental parameters

Products for this application meet the following requirements.

Criteria by EN 12405-1:2018

Electromagnetic Compatibility, immunity

Electrostatic Discharge (ESD):

EN 61000-4-2

Contact ±8 kV

Air ±15 kV

Conducted Radio Frequency:

EN 61000-4-6

0,15 ... 80 MHz – 10 V

Radiated Electromagnetic Field:

EN 61000-4-3

80 ... 1 000 MHz – 10 V/m

1 ... 2,700 GHz – 10 V/m

Magnetic Field:

EN 61000-4-8

100 A/m – direct

1000 A/m – for 3 s

Level 5

Electrical Fast Transient (Burst):

EN 61000-4-4

±2 kV, I/O

Electrical Slow Transient (Surges)

EN 61000-4-5

±2 kV

Short drops in electrical supply

EN 61000-4-29

Level 1

Climatic Immunity

The transmitters can be installed in different climatic conditions in environments of varying humidity, also in areas of water vapour condensation.

Environment temperature:

EN 60068-2-1, EN 60068-2-2,

EN 60068-3-1

hot: T = 55 °C, R_H = max 55 %

cold: T = -25 °C

Humid Permanent Heat:

EN 60068-2-78

T = 55 °C, R_H = 93 %, 96 h

Damp Heat Cycle:

EN 60068-2-30

(T = 22 ÷ 55 °C, R_H = 80 ÷ 100 %, 24h)x2

Mechanical Immunity

Shocks:

EN 60068-2-31, Level 2

Vibrations in a wide band:

EN 60068-2-64, test Fh, Level 2

9. OPERATION



The IP 66 degree of the transmitter housing protection for applications with gaseous fuels from 1 and 2 families in accordance with EN 437 Standard is ensured by the housing design as well as cable entries and plugs with HNBR or NBR seals. When you intend to use own cable inlets and plugs, you should use components dedicated to Ex zones, guaranteeing compliance with the requirements regarding: ambient temperatures, resistance to gaseous fuels, families 1 and 2 and IP degree.

The transmitter gives the possibility of rotating the housing – to do this, loosen the screw (item 1), position the transmitter housing (item 2) as required, tighten the screw (item 1). The transmitter body can be rotated max. by 330°. It is also possible to adjust the position of the display to the mounting position of the body. The module can be rotated $\pm 180^\circ$ with 90° step. To do this, tighten the cover screw (item 5), unscrew the front cover (item 3) and two display screws (item 6), then use them to pull the module out. Rotate the taken out module and insert it back into the lower housing of the display electronics assembly, then tighten the display screws and cover.

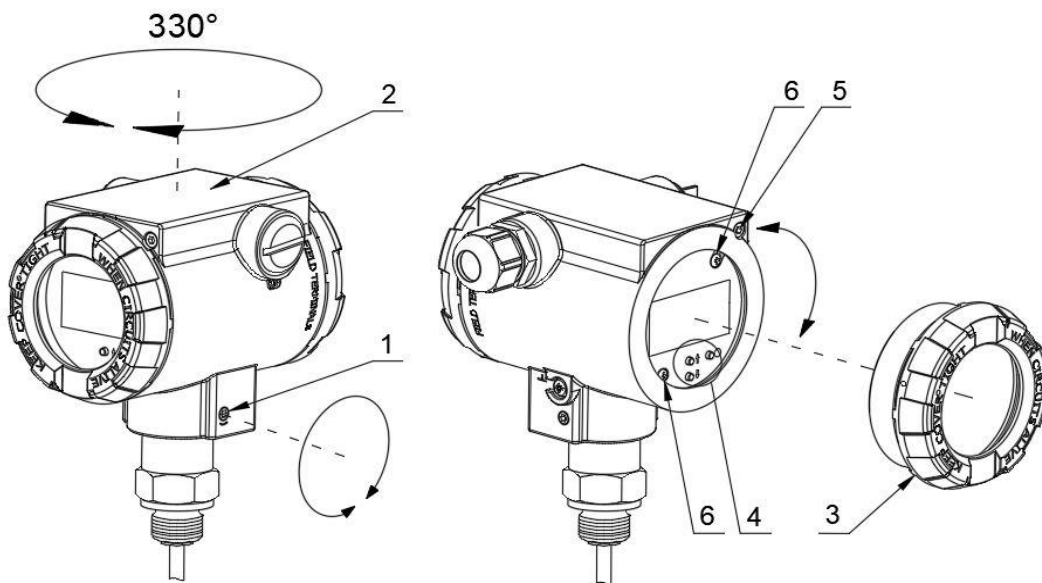

Figure 7. Rotation of the housing, change of display position and access to buttons

1. Screw blocking display rotation.
2. Transmitter housing.
3. Front cover.
4. Local buttons.
5. Screw blocking front cover unscrewing.
6. Display screws



In hazardous zone, do not unscrew the housing covers after connecting the Exd flame-proof transmitter to the power source.

9.1. Local LCD display

The LCD has three primary information fields identified in the figure below as LCD1, LCD2, LCD3.

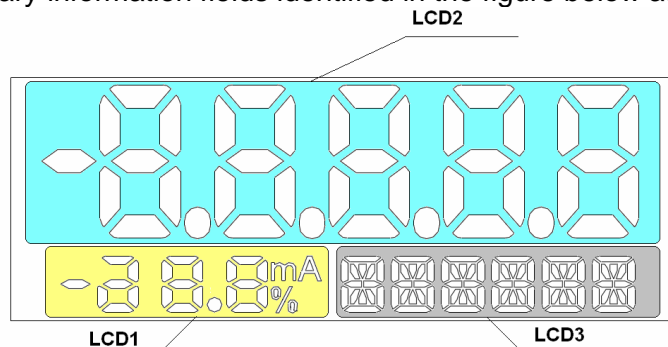

Figure 8. Display information fields

LCD1 field:

[mA] – value (milliamperes) of process current in line 4 ... 20 mA, proportional to the measured temperature.

[%] – value (percentage) of the setpoint $U(t)$ of current controller in current loop 4 ... 20 mA. This value is the ratio of the process current $I_p(t)$ to the current range width according to the following formula:

$$\%U(t) = \frac{I_p(t) - 4 \text{ [mA]}}{16 \text{ [mA]}} \cdot 100[\%]$$

LCD2 field:

The LCD2 field is used mainly to display floating point decimal values of process variable in a unit displayed on LCD3. In some cases, other messages may be displayed:

- **ERROR** in case of some operating errors or failure diagnosed in the transmitter, error/failure number **Exxxx** will appear on LCD2, the **ERROR** message will be displayed on LCD3. The image will blink to attract the operator's attention. The transmitter will set the current output to alarm status.
- **undEr** if the limit below LRV of the set range in MID mode is exceeded by the process, the LCD1 display of transmitter will show the message **undEr** (under). The image will blink to attract the operator's attention. The transmitter will set the current output to alarm status.
- **ouEr** if the limit above URV of the set range in MID mode is exceeded by the process, the LCD1 display of transmitter will show the message **ouEr** (over). The image will blink to draw the operator's attention.
- ● ● ● ● when the set position of comma (point) on LCD2 does not allow for the correct display of the process variable, four dots ● ● ● ● will appear on LCD. The image will blink to attract the operator's attention. In this situation, change the decimal point position in the local setpoint change MENU or via HART communication.

LCD3 field:

During normal operation it is designed for continuous display of the base unit or the user units. In the MENU operation mode it displays the setting options. It is also used to display errors related to the execution of commands in the local setup MENU.

9.2. Local buttons

Local buttons are used to enable the configuration mode of some transmitter parameters and to navigate through MENU and accept MENU options. The MENU can be accessed by pressing and holding any of the buttons for at least 4 seconds. After this time, the LCD3 field of the local display will show an **EXIT** message. This signals entering into the MENU navigation mode.

9.3. Local configuration of setpoints

Transmitter enables local configuration of some of the most common setpoints via local buttons and local LCD display.

9.4. Navigation in local setpoints MENU

The MENU can be accessed by pressing and holding any of the buttons for at least 4 seconds. After this time, the LCD3 field of the local display will show an **EXIT** message. This signals entering into the local configuration MENU. By pressing the buttons with arrows [↑] [↓] for at least 1 second you can move up or down in MENU.

9.5. Acceptance of local setpoints

The button marked with symbol [●] is used to accept the selection. The acceptance of setpoint change is confirmed by a **DONE** message displayed on LCD3. After changing the setpoint, the transmitter leaves the local configuration change MENU. If no selection is made in the MENU mode, after 2 minutes the transmitter automatically returns to display of standard messages. The MENU can also be left by selecting and accepting the **EXIT** option.

9.6. Structure of local setpoints MENU

When navigating in the area of the active local MENU, holding the button required to trigger the action is minimum 1 second. Continuous pressing of the [↑] or [↓] button results in scrolling of the MENU positions every 1 second. If the local MENU remains inactive for more than 2 minutes, after this time the transmitter will automatically leave the MENU mode and will display the process variable.

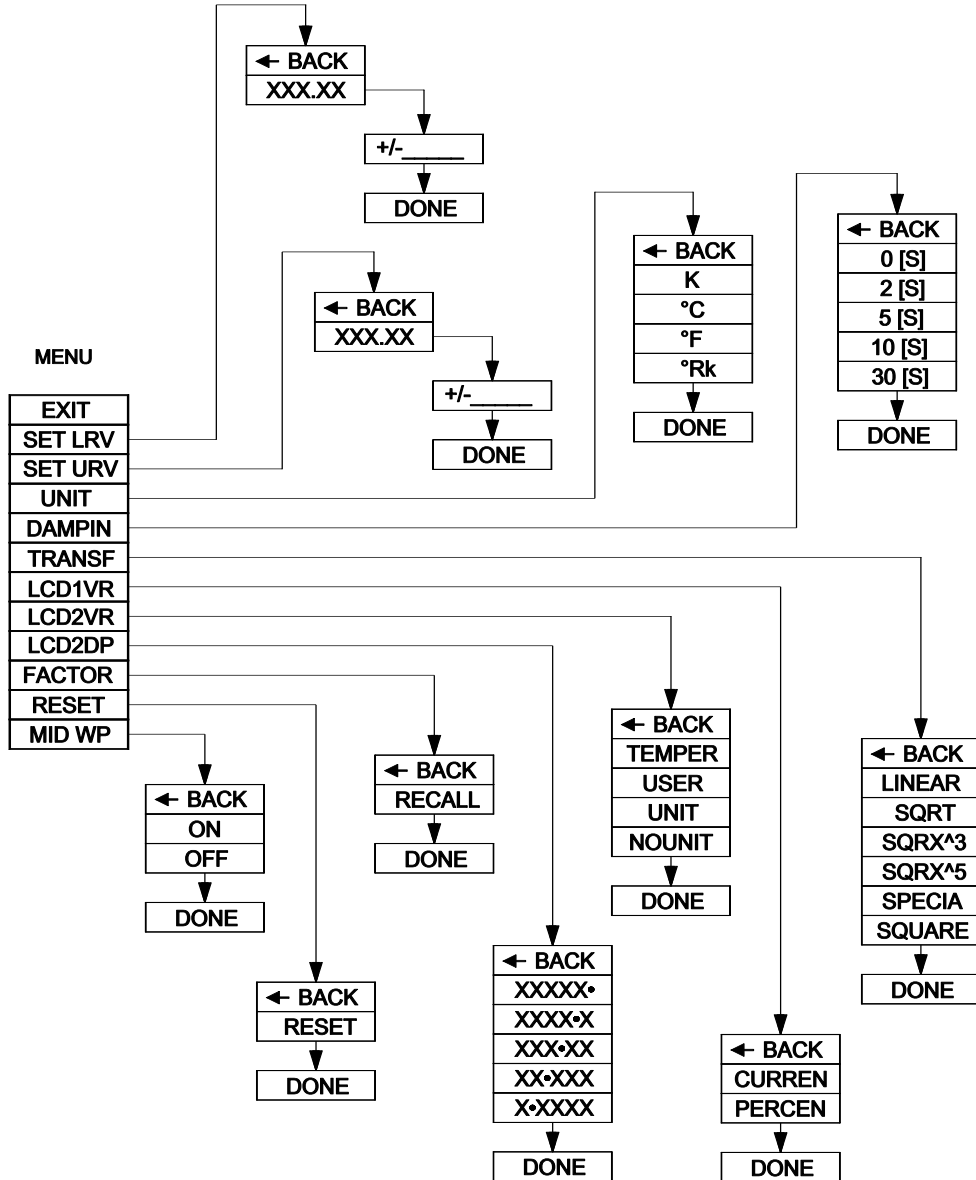

Figure 9. Structure of local setpoints menu of the transmitter

Table 5. Explanation of menu items

Local Menu	Submenu	Description
EXIT		Return from the Local Menu to display the process variable
SET LRV / SET URV		Setting the start of the range set to LRV / Setting the finish of the range set to URV
	XXX.XX	The current LRV/URV value is displayed
	+/-_____	Select and confirm the sign of the parameter to be entered; enter digit by digit, 5-digit number with or without a dot; after confirming the last 5th digit of the parameter, the transmitter will confirm acceptance of the command with "DONE" or will report an error number; the parameter is entered in "UNIT" units".
UNIT		Setting of temperature units.
DAMPIN		Setting of the constant time damping of the process variable.
TRANSF		Setting the linearization type of current processing characteristics.
	LINEAR	Linear characteristics.
	SQRT	Square root function.
	SQRX^3	Square root function of x^3 .
	SQRX^5	Square root function of x^5 .
	SPECIA	Linearization of the user board output.
ALARM		Setting the transmitter alarm current value.
	LOW	Low alarm current.
	HIGH	High alarm current.
	LAST	Last value.
	CUSTOM	Alarm current value set by user.
LCD1VR		Type of process variable displayed on LCD1.
	CURREN	The LCD1 displays the current value in the current loop.
	PERCEN	The LCD1 displays the percentage of output control.
LCD2VR		Type of variable displayed on LCD2.
	TEMPER	The LCD2 displays process variable.
	USER	The LCD2 will display the scaled value in user units.
	UNIT	The LCD2 displays actual unit and process variable alternately.
LCD2DP		The LCD2 does not display actual unit and process variable alternately.
FACTORY		Position of the decimal dot of the variable displayed on LCD2.
RESET		Removes user's calibration coefficients of temperature and current, returns to factory settings.
MID WP		Forced transmitter reset by software.
		Setting write lock parameters.

9.7. Remote configuration of setpoints (HART)

The transmitter allows to read out and configure the parameters via HART communication using 4 ... 20 loop as a physical layer for FSK BELL 202 modulation.

9.7.1. Compatible devices

The following devices may be used to communicate with the transmitter:

- Aplisens S.A. KAP-03, KAP-03Ex communicator;
- communicators from other companies, including those using DDL and DTM libraries;
- PC computers equipped with HART modem (e.g. HART/USB converter by Aplisens S.A.) with Windows 7 or Windows 10 operating system with installed Raport 2;
- PC computers equipped with HART modem using software from other companies, accepting DDL and DTM libraries;
- smartphones with Android system, using a converter providing wireless communication (e.g. HART/USB converter by Aplisens S.A.) using Aplisens Mobile Configurator. The software is available on Google Play under the link:
<https://play.google.com/store/apps/details?id=com.aplisens.mobile.amc>.

9.7.2. Compatible configuration software

- Raport 2 Aplisens under control of Windows 7 or Windows 10;
- Aplisens Mobile Configurator under control of the Android system;
- softwares from other companies accepting DDL and DTM libraries.

9.7.3. Local HART communication jumper

The transmitter allows to use the local HART communication. To do this you can use a HART communicator unit or modem interoperating with a computer or a smartphone.

In order to establish communication, it is necessary to:

- remove the HART communication jumper (→ [Figure 3. Electrical connection to transmitter](#));
- connect the communicator or modem to terminals (→ [7.1.2. Connection of transmitter with the option of using local HART communication](#)).

10. EXPLOSIONPROOF PARAMETERS

10.1. Transmitters with Exd protection

Transmitters are made in accordance with the requirements of the following standards:

EN IEC 60079-0:2018-09, EN 60079-1:2014-12, EN 60079-11:2012, EN 60079-26:2015-04.

10.2. Transmitter explosion-proof marking

Transmitters can operate in potentially explosive areas, in accordance with the assigned marking (feature) of explosion-proof construction:



II 1/2 G Ex ia/d IIC T* Ga/Gb
KDB 10 ATEX 122X

$25\text{ °C} \leq T_a \leq +45\text{ °C} / +55\text{ °C}$

T* – temperature class of transmitter

10.3. Category of transmitter and hazard zones

1/2G transmitter category means that transmitter can be installed in 1 or 2 hazard zone and the transmitter process connection can be connecting to 0 zone. Example on the → [Figure 10. Mounting the transmitter in zones](#).

10.4. Power supply and exploitation of transmitter



Electrical connections of transmitters in danger zone should be made by people who have indispensable knowledge and experience in this branch. Earth clamps must be used to earth transmitters. In the event that transmitters come in good electrical contact with structural metal parts or metal pipes which are connected to the equipotential bonding system, transmitters do not require to be earthed.



Transmitters should be supplied from DC electrical source with voltage max. 45 V DC (nominal 24 V DC) from transformer feeders or other devices which have at least a strengthened isolation among primary and secondary windings in which there is no voltage higher than 250 V AC. The duty of power supply installation with mentioned requirements rests on user.

10.5. Measurement of operating temperature of transmitter



After installing the APT-2000ALW transmitters for the maximum expected medium temperature and the maximum expected ambient temperature, measure out T_p (temperature of the hottest place on the surface of transmitter) and determine the transmitter temperature class according to → [10.6. Determination of the temperature class T* of the transmitter for gas](#). When measuring the warmed media, above ambient, is recommended to determine the temperature of the stub while is screwed into the transmitter or at the wall of the pipe/tank.

When medium is heated above ambient temperature, it is allowed to determine the temperature class of the transmitter T_p through the adoption of a maximum temperature of the medium which is provided by the technological process. Then measurement of temperature T_p is not necessary.

If during the measurement of T_p for maximum temperature expected for the medium is not possible to ensure the maximum expected ambient temperature, after the measurement of T_p one can estimate the potential growth in temperature T_p due to the increase of ambient temperature.

If the other elements of the plant have or may have a temperature higher than the highest temperature T_p on the transmitter, security conditions must be ensured in accordance with accepted principles in such cases.

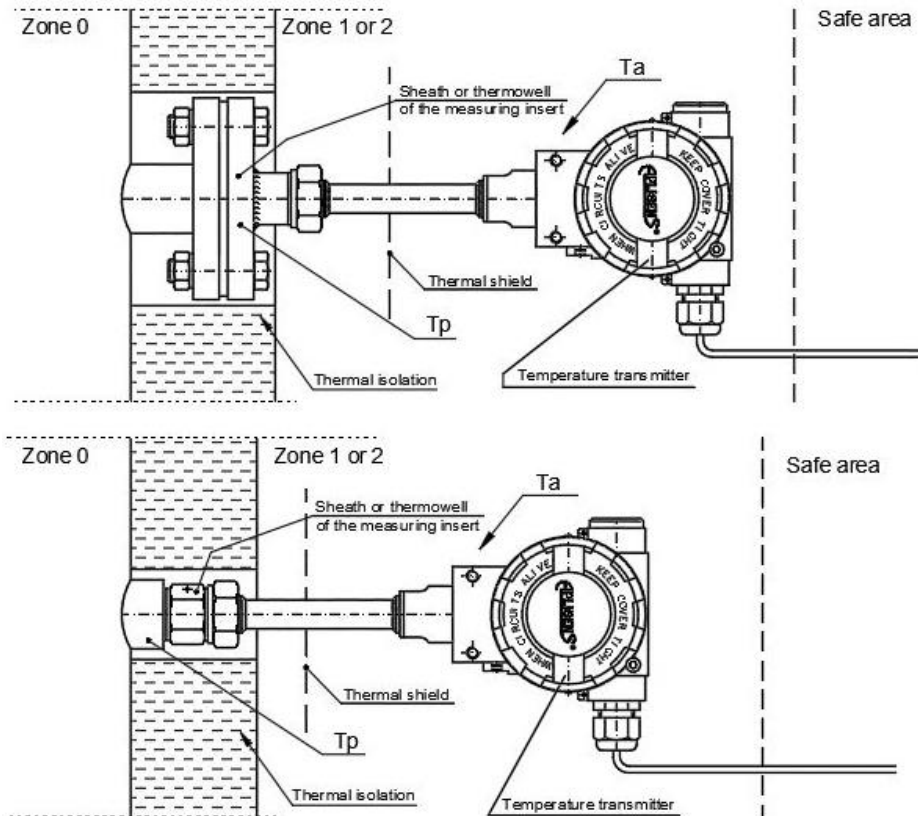

Figure 10. Mounting the transmitter in zones

10.6. Determination of the temperature class T^* of the transmitter for gas

Determine the transmitter temperature class for gas in relation to temperature T_p due to formula:

$$T^* \geq T_p + 0,1T_p + 5 \text{ K} \quad \text{for class T3 ... T6}$$

$$T^* \geq T_p + 0,1T_p + 10 \text{ K} \quad \text{for class T1, T2}$$

The following table contains values of permissible ambient temperature depending on the temperature T_p and temperature class of the transmitter.

T_p [°C]	Temperature class and ambient temperature T_a [°C]	
$T_p \leq 75 \text{ °C}$	T6	$T_a = 45 \text{ °C}$
	T5	$T_a = 75 \text{ °C}$
$T_p \geq 75 \text{ °C}$	T5, T4	$T_a = 70 \text{ °C}$
	T3, T2	$T_a = 65 \text{ °C}$
	T1	$T_a = 60 \text{ °C}$

T_p – transmitter temperature measured in → 10.5. Measurement of operating temperature of transmitter.

In the case of significant increase in medium temperature, measurement of T_p must be executed again and the temperature class for gas must be specified again.

10.7. List of cable glands and plug replacements

As standard, the transmitters in Exd version are delivered without a cable gland, with blanking plugs approved in certification process.

Used cable glands and blanking plugs must comply with the transmitter documentation approved by the validation process.



The list of cable glands and plugs complied with producer documentation are given in the tables below.

The installer is responsible for installing the cable glands and blanking plugs in accordance with the environment and ATEX requirements.

Table 6. List of cable glands

Type	Producer	Screw	Feature	IP	Certificate No.
501/423	Hawke International	M20x1.5 (1/2" NPT)	Exd IIC Gb Extb IIIC Db	67	CML 19ATEX1167X
501/421	Hawke International	M20x1.5 (1/2" NPT)	Exd IIC Gb Extb IIIC Db	67	CML 19ATEX1167X
ICG 623	Hawke International	M20x1.5 (1/2" NPT)	Exd IIC Gb Extb IIIC Db	67	Baseefa 06ATEX0058X
501/453/RAC	Hawke International	M20x1.5 (1/2" NPT)	Exd IIC Gb Extb IIIC Db	67	CML 19ATEX1167X
501/453/Universal	Hawke International	M20x1.5 (1/2" NPT)	Exd IIC Gb Extb IIIC Db	67	CML 18ATEX1268X
ICG/653/Universal	Hawke International	M20x1.5 (1/2" NPT)	Exdb IIC Gb Extb IIIC Db	67	CML 18ATEX1268X
ICG/653/Universal/L	Hawke International	M20x1.5 (1/2" NPT)	Exd IIC Gb Extb IIIC Db	67	CML 18ATEX1268X
A2F, A2FRC	CMP-Products	M20x1.5 (1/2" NPT)	Exd IIC Gb Exta IIIC Da	67	CML 18ATEX1321X
SS2K	CMP-Products	M20x1.5 (1/2" NPT)	Exd IIC Gb Exta IIIC Da	67	CML 18ATEX1321X
E1FW, E2FW	CMP-Products	M20x1.5 (1/2" NPT)	Exd IIC Gb Exta IIIC Da Exd I Mb	67	CML 18ATEX1324X
PX2K, PXSS2K, PX2KX	CMP-Products	M20x1.5 (1/2" NPT)	Exdb IIC Gb Exta IIIC Da Exdb I Mb	67	CML18ATEX1325X

Table 7. List of blank plug replacements

Blanking plug type	Producer	Screw	Feature	IP	Certyfikate No.
475	Hawke International	M20x1.5 (1/2" NPT)	Exd IIC Gb Extb IIIC Da Exd I Mb	67	Baseefa 10ATEX0262X
477	Hawke International	M20x1.5 (1/2" NPT)	Exd IIC Gb Extb IIIC Da Exd I Mb	67	Baseefa 10ATEX0262X
747, 757, 767	CMP-Products	M20x1.5 (1/2" NPT)	Exd IIC Gb Exta IIIC Da Exd I Mb	67	CML 18ATEX1320X

During the installation, the M20x1.5 thread of cable glands should be sealed with LOCTITE243 adhesive. For cable glands with 1/2" NPT tread the LOCTITE 577 or SWAK MS-PTS-50 sealant should be used.

10.8. Specific conditions of use

Permissible gap of flame proof joint marked L4 is less than defined in norm EN 60079-1:2007 and cannot be greater than value passed on → [Figure 11. Flameproof joints.](#)

Temperature class (T* for gas) depends mainly on the temperature of the process (temperature of the controlled medium) and the method of installation on site. Therefore, to determine the temperature Tp (hottest place on the surface of the transmitter housing, practically cover of the sensor) that is in contact with explosive atmosphere in conditions of installation in site and proceed in accordance with → 10.5. Measurement of operating temperature of transmitter.

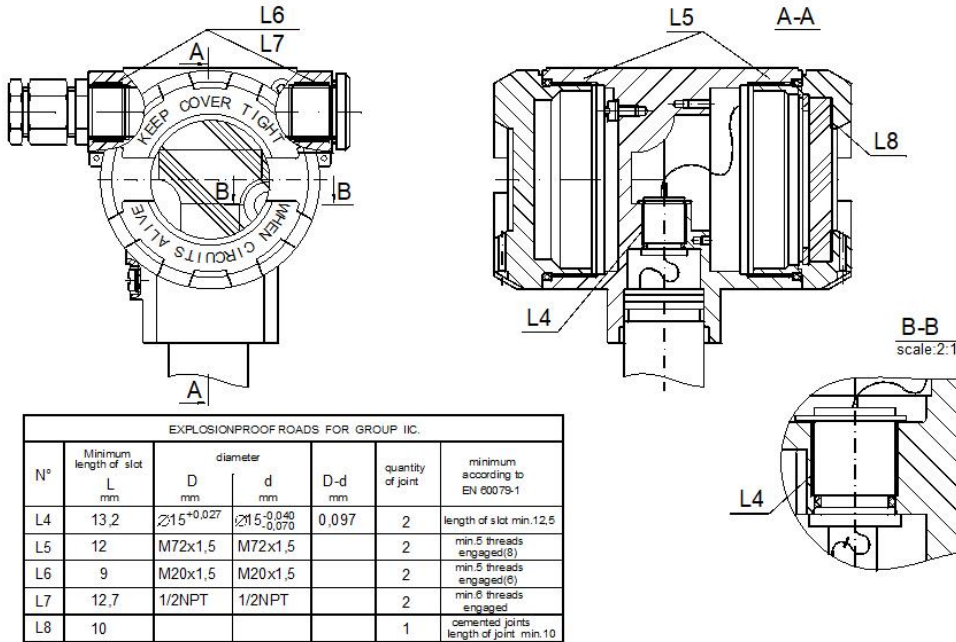

Figure 11. Flameproof joints

The general principles of connecting and exploitation of transmitters in Exd realization should be compatible with principles and relating standards for Exd housing devices mentioned in → 10.1. Transmitters with Exd protection, including also IEC 60079-14, IEC 60079-17.

10.9. Transmitters with Exi protection

Transmitters are made in accordance with the requirements of the following standards: EN IEC 60079-0: 2018-09, EN 60079-11: 2012

10.10. Transmitter explosion-proof marking

Transmitters can work in potentially explosive atmospheres in accordance with the marking of the type of explosion-proof structure:

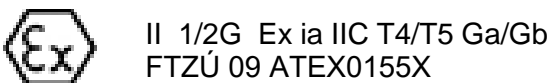

The 1/2G transmitter category in the marking indicates that transmitter can be installed in the 1 or 2 hazard zone. Transmitter process connection can be connect to 0 zone.

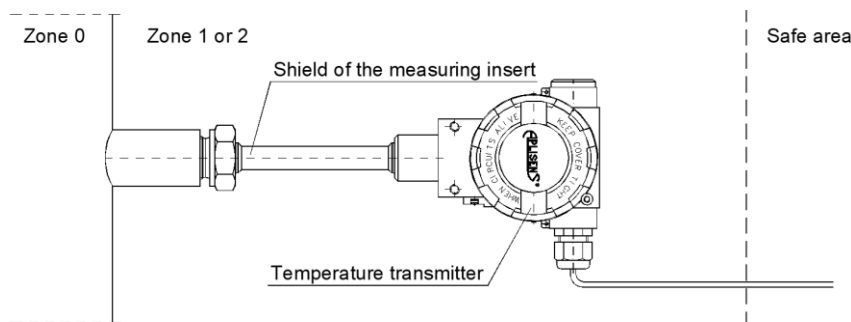

Figure 12. Mounting the transmitter in zones

10.11. U_i, I_i, P_i supply parameters and temperature classes

The transmitters should be powered via the associated power feeding and measurement devices provided the relevant intrinsic-safe certificates. The parameters of their outputs to the danger zone should not exceed the limit of power supply parameters for the below specified transmitters. Temperature classes T4, T5 depends on the input power and maximum ambient temperature.

Supply with linear output characteristics:

$$U_i = 30 \text{ V} \quad I_i = 0,1 \text{ A} \quad P_i = 0,75 \text{ W} \quad T_a \leq 80 \text{ }^\circ\text{C} \text{ \& } T4, T_a \leq 55 \text{ }^\circ\text{C} \text{ \& } T5$$

An example of a supply with a linear characteristic is a typical barrier with parameters:

$$U_o = 28 \text{ V}, I_o = 0.093 \text{ A}, R_w = 300 \text{ } \Omega.$$

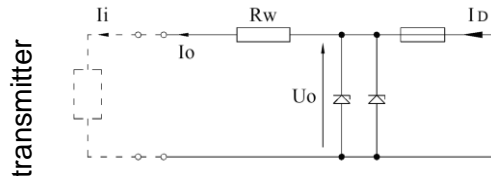

Figure 13. The principle of feeding from a source with a linear characteristic

Supply with a trapezoidal output characteristics:

$$U_i = 24 \text{ V} \quad I_i = 50 \text{ mA} \quad P_i = 0,6 \text{ W} \quad T_a \leq 55 \text{ }^\circ\text{C} \text{ i } T5$$

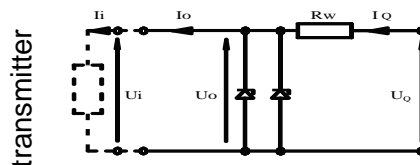

Figure 14. The principle of feeding from a source with a trapezoidal characteristic

If $U_o > 0,5U_Q$, then U_Q, I_o, P_o have the following relations:

$$P_o = \frac{U_Q \cdot I_o}{4}$$

If $U_o \leq 0,5U_Q$, then U_Q, I_o, P_o have the following relations:

$$P_o = \frac{U_o(U_Q - U_o)}{R_w}$$

Resistance R_w :

$$R_w = \frac{U_Q}{I_o}$$

For power supply with a rectangular output characteristic:

$$U_i = 24 \text{ V} \quad I_i = 25 \text{ mA} \quad P_i = 0,6 \text{ W} \quad T_a \leq 55 \text{ }^\circ\text{C} \text{ \& } T5$$

The supply of power from a source with a rectangular characteristic means that the voltage of the Ex power supply remains constant until current limitation activates.

The protection level of power supplies with a rectangular characteristic is normally "ib". The transmitter powered from a such supply is also an Ex device with "ib" protection level.

Example of practical provision of power supply:

stabilized power supply with $U_o = 24 \text{ V}$, protection level "ib", and current limited to $I_o = 25 \text{ mA}$.

Input capacity and inductance of the transmitter:

$$C_i = 30 \text{ nF}, L_i = 0,75 \text{ mH}$$

Transmitters operating temperature range: $-25 \text{ }^\circ\text{C} \leq T_a \leq 55 \text{ }^\circ\text{C}$.

11. MAINTENANCE

11.1. Periodic inspections

Periodic inspections shall be carried out in accordance with applicable standards. During the inspection, the condition of the process (absence of loosened elements and leaks) and electrical (check of connections reliability and condition of gaskets and glands) connectors and stability of fixing of the housing and mounting bracket (if used) shall be checked. Check the processing characteristics by performing the operations specific for the CALIBRATION and possibly CONFIGURATION procedure.

11.2. Non-periodic inspections

If the transmitter at the installation site has been exposed to mechanical damage, overvoltage or incorrect operation of the transmitter has been detected, the device should be inspected. Check the electrical functionality of the transmitter and the processing characteristics.



If there is no signal in the transmission line or its value is improper, check the supply line, connection status on terminal blocks, connectors, etc. Check if the supply voltage and load resistance are correct.

11.3. Cleaning/washing

To remove impurities from the external surfaces of the transmitter wipe it with a cloth dampened in water.

11.4. Spare parts

Parts of the transmitter that may be worn or damaged and thus replaced: cover seals.



Other parts, in the case of ATEX type of transmitter, may be replaced only by the manufacturer or an authorized representative.

11.5. Repair

Faulty or non-operational transmitter shall be provided to the manufacturer or authorized representative.

11.6. Returns

In the following cases, the transmitter should be returned directly to the manufacturer:

- need for repair;
- need for factory calibration;
- replacement of improperly selected/shipped transmitter.

12. SCRAPPING, DISPOSAL



Worn or damaged devices shall be scrapped in accordance with WEEE Directive (2012/19/EU) on waste electrical and electronic equipment or returned to the manufacturer.

13. HISTORY OF REVISIONS

Revision No.	Document revision	Description of changes
-	01.A.001/2023.01	Initial document version. Prepared by DBFD.
1	01.B.001/2024.09	Changing Exi parameters.